

*An Online PDH Course
brought to you by
CEDengineering.com*

HVAC – How to Size and Design Ducts

Course No: M06-048

Credit: 6 PDH

A. Bhatia



Continuing Education and Development, Inc.

P: (877) 322-5800

info@cedengineering.com

HVAC

HOW TO SIZE AND DESIGN DUCTS



CONTENTS

1.0. DUCTWORK DESIGN PRINCIPLES

- 1.1 Basic Definitions
- 1.2 Air Flow Principles
- 1.3 Total Pressure, Velocity Pressure, and Static Pressure
- 1.4 Air Flow Characteristics in Duct

2.0. DUCT COMPONENTS & MATERIALS

- 2.1 Duct Components
- 2.2 Duct Materials

3.0. DUCT CLASSIFICATION

- 3.1 Velocity Classification
- 3.2 Pressure classification
- 3.3 Velocity classification v/s Pressure classification

4.0. DUCT SHAPES

- 4.1 Round Ducts
- 4.2 Rectangular Ducts
- 4.3 Oval Ducts
- 4.4 Equivalent Diameter

5.0. DUCT SIZING

- 5.1 Equal friction method
- 5.2 Velocity Reduction Method
- 5.3 Static Regain Method

6.0. PRESSURE LOSSES IN AIR DISTRIBUTION SYSTEM

- 6.1 Duct Friction Losses
- 6.2 Duct Fitting Dynamic Losses
- 6.3 The Concept of Duct Equivalent Length

6.4 Pressure Loss across Components

7.0. FAN SIZING

7.1 Fan Selection Example

7.2 Balancing Air

7.3 Fan System Effect

8.0. THE SUPPLY DUCT SYSTEM

8.1 Extended Plenum Systems

8.2 Reducing Plenum System

8.3 Reducing Trunk System

8.4 Spider System

8.5 Radial System

8.6 Perimeter Loop System

8.7 Rules of Duct Design (ACCA Manual D – Residential Duct Systems)

9.0. RETURN DUCT SYSTEMS

9.1 Distributed Return

9.2 Central Return

9.3 Pressure Balancing

10.0. DUCT FITTINGS AND TERMINAL UNITS

10.1 Duct Fittings and Transitions

10.2 Volume Control Dampers

10.3 Fire and Smoke Dampers

10.4 Diffusers, Grilles & Registers

10.5 Location of Air Inlets and Outlets

11.0. DUCT CONSTRUCTION & REINFORCEMENT

11.1 Duct Construction

11.2 Duct Sheet Metal Thickness

- 11.3 Aspect Ratio
- 11.4 Standard Duct Sizes
- 11.5 Duct Fabrication and Lengths
- 11.6 Duct Hanger Spacing

12.0. GOOD ENGINEERING PRACTICES

- 12.1 Energy Conservation
- 12.2 Good Engineering Practices for Designing Ductwork

13.0. DUCTWORK INSULATION AND SEALING

- 13.1 Ductwork Insulation
- 13.2 Ductwork Air Leakage
- 13.3 Duct Leakage Tests
- 13.4 Duct Sealing

14.0. DUCT ATTENUATION AND NOISE CONSIDERATIONS

- 14.1 HVAC Noise Points
- 14.2 Acoustical Analysis of a Ductwork System

15.0. DUCTWORK TESTING & SYSTEM PERFORMANCE

- 15.1 Balancing the System
- 15.2 Testing Methods and Equipment
- 15.3 Air Flow Measurement Instruments
- 15.4 Determining Air Flow at Grilles
- 15.5 Determining Air Flow in Ducts
- 15.6 Provisions during Design for Testing, Adjusting, and Balancing

16.0. DUCT CLEANING

- 16.1 Duct Cleaning Methods
- 16.2 Coordination between Design Specialties

HVAC – HOW TO SIZE AND DESIGN DUCTS

Air flow problems have plagued the HVAC industry for years. No matter how much money you spend on a high-quality HVAC system, the equipment won't work at its best without properly designed and installed ductwork. Ducts that are not well designed result in discomfort, high energy costs, bad air quality, and increased noise levels.

A well-designed ductwork system should deliver maximum interior comfort at the lowest operating cost while also preserving indoor air quality. The chief requirements of an air conditioning duct system are:

1. It should convey specified rates of air flow to prescribed locations.
2. It should be economical in combined initial cost, fan operating cost and cost of building space.
3. It should not transmit or generate objectionable noise.

A primary issue is the tradeoff between the initial cost of the duct system and the energy cost of the air distribution system. Larger ducts require a larger initial investment, but result in lower fan energy costs over the life of the system. Other issues include space restrictions, noise level, capacity for expansion, appearance, etc.

This course will discuss the basic fundamentals and principles of air conditioning duct design and layout.

1.0. DUCTWORK DESIGN PRINCIPLES

Starting with the basics, let's start at the most elementary level of air flow fundamentals.

1.1 Basic Definitions

The following basic terminology is extensively used in this course.

- **cfm:** volume of air flow; cubic feet/minute
- **fpm:** velocity or speed of air flow; feet/minute
- **sq.ft:** duct size or cross-sectional area; square feet

Air volume in cfm can be calculated by multiplying the air velocity by the cross-sectional area of the duct in square feet.

- $\text{cfm} = \text{fpm} \times \text{Area}$

Given any two of these three quantities, the third can be readily determined:

- $\text{fpm} = \text{cfm}/\text{area}$
- $\text{Area} = \text{cfm}/\text{fpm}$

Gauge and Absolute Pressures:

Gauge pressure is indicated on the gauge; absolute pressure is the total of the indicated gauge pressure plus atmospheric pressure. The general equation for absolute pressure is:

$$\text{Gauge pressure} + \text{atmospheric pressure} = \text{absolute pressure}$$

For example, if the gauge reads 10 psig then, using the above equation, the absolute pressure would be 24.7 psia:

$$10 \text{ psig} + 14.7 \text{ psi} = 24.7 \text{ psia}$$

Ordinary heating, ventilating, and air conditioning duct systems read air pressures at 0.4 psi or less, often much less. 1 psi equals 27.7 inches of water gauge; a common duct pressure of 0.25 inches water column is equal to $(0.25 \text{ divided by } 27.7 \text{ in-wc/psi}) = 0.009 \text{ psi}$.

Duct Pressure:

Duct system is pressurized by three pressures:

- **Static pressure:** It is the air pressure in the duct, which is used for fan selection.
- **Velocity pressure:** It is the pressure generated by the velocity and weight of the air, which is used for measuring the flow (cfm) in a system.
- **Total pressure:** It is used to find velocity pressure. Static pressure plus velocity pressure equals total pressure.

Pressure in the ductwork is measured in inches of water column (in-wc).

Standard Air Density:

Air has mass. Standard air has a density of 0.075 lbs/ ft³.

System capacity is directly affected by changes in air flow. As air is heated or humidified, its specific volume increases and its density decreases. If the air density is low, more

cfm is required to keep the mass flow rate the same. If air density is not considered, many systems will have very low air flow.

Correction for the density is however not needed in air conditioning or cooling applications, if the temperature is between 40°F to 100°F and up to 1000 ft. in elevation.

Fan Capacity:

The volume of air will not be affected in a given system because a fan will move the same amount of air regardless of the air density. In other words, if a fan will move 3,000 cfm at 70°F, it will also move 3,000 cfm at 250°F

Volumetric Air Flow Rate:

The volumetric flow rate of air that will be conveyed through the duct in an air conditioning system is determined by the cooling/heat load and the desired supply air temperature. Since we are not conditioning cfm's of air but rather pounds of it, we need a mass-balance equation:

$$Q \left[\frac{Btu}{h} \right] = \dot{m} \left[\frac{lb}{hr} \right] c_p \left[\frac{Btu}{\text{°F} * lb} \right] \Delta T [^{\circ}\text{F}]$$

$$Q \left[\frac{Btu}{h} \right] = CFM * \left(60 \frac{min}{hr} \right) * \left(\frac{0.075 lbm}{ft^3} \right) 0.24 \left[\frac{Btu}{\text{°F} * lb} \right] \Delta T [^{\circ}\text{F}]$$

air conditions at 70°F and 1 atm.

$$Q \left[\frac{Btu}{h} \right] = 1.08 * CFM * \Delta T [^{\circ}\text{F}]$$

It is important that the air conditioning ductwork system delivers and return the right amount of air from each room and provide comfort year round. This implies room by room heat loss and heat gain calculations.

1.2 Air Flow Principles

Flow of air is caused as a result of pressure differential between two points. Flow will originate from an area of high energy (or pressure) and proceed to area(s) of lower energy.

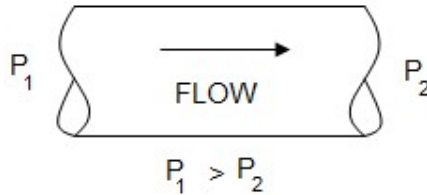

Air moves according to three fundamental laws of physics: conservation of mass, conservation of energy, and conservation of momentum.

1. **Conservation of mass:** It simply states that an air mass is neither created nor destroyed. From this principle it follows that the amount of air mass coming into a junction in a ductwork system is equal to the amount of air mass leaving the junction, or the sum of air masses at each junction is equal to zero. In most cases the air in a duct is assumed to be incompressible, an assumption that overlooks the change of air density that occurs as a result of pressure loss and flow in the ductwork. In ductwork, the law of conservation of mass means a duct size can be recalculated for a new air velocity using the simple equation:

$$V_2 = (V_1 * A_1)/A_2$$

where V is velocity and A is Area

2. **The law of energy conservation:** It states that energy cannot disappear; it is only converted from one form to another. This is the basis of one of the main expressions of aerodynamics, the Bernoulli equation. Bernoulli's equation in its simple form shows that, for an elemental flow stream, the difference in total pressures between any two points in a duct is equal to the pressure loss between these points, or:

$$(\text{Pressure loss})_{1-2} = (\text{Total pressure})_1 - (\text{Total pressure})_2$$

3. **Conservation of momentum:** It is based on Newton's law that a body will maintain its state of rest or uniform motion unless compelled by another force to change that state. This law is useful to explain flow behavior in a duct system's fitting.

1.3 Total Pressure, Velocity Pressure, and Static Pressure

Air flow through a duct system creates three types of pressures: static, dynamic (velocity), and total.

1. **Static pressure:** Static Pressure is the pressure that causes air in the duct to flow. Static pressure is the outward push of air against duct surfaces and is a measure of resistance when air moves through an object like duct work. Measured in inches of water column (in-wc), it acts equally in all directions and is independent of velocity.
2. **Velocity pressure:** Velocity pressure is the pressure caused by air in motion. It is equal to the product of air density and the square of the velocity divided by 2.

$$VP = 0.5 \times \rho \times v^2$$

Using standard air, the relationship between V and VP is given by:

$$VP = \left(\frac{v}{4005} \right)^2$$

VP will only be exerted in the direction of air flow and is always positive.

3. **Total Pressure:** Total pressure is the algebraic sum of velocity pressure and static pressure.

$$TP = VP + SP$$

- **TP** = Total Pressure
- **VP** = Velocity Pressure
- **SP** = Static Pressure

1.4 Air Flow Characteristics in Duct

1. At any point, the total pressure is equal to the sum of the static and velocity pressures.
2. The static pressure is exerted equally in all directions and the velocity pressure is exerted only in the direction of air flow. This makes it difficult to directly measure velocity pressure in a duct. Simply put, because static pressure is also pushing in the direction of air flow, you can never measure just velocity pressure. Practically, velocity pressure is calculated by measuring pressure perpendicular to the air flow (Static Pressure) and also measuring pressure parallel to the air flow (Total Pressure).

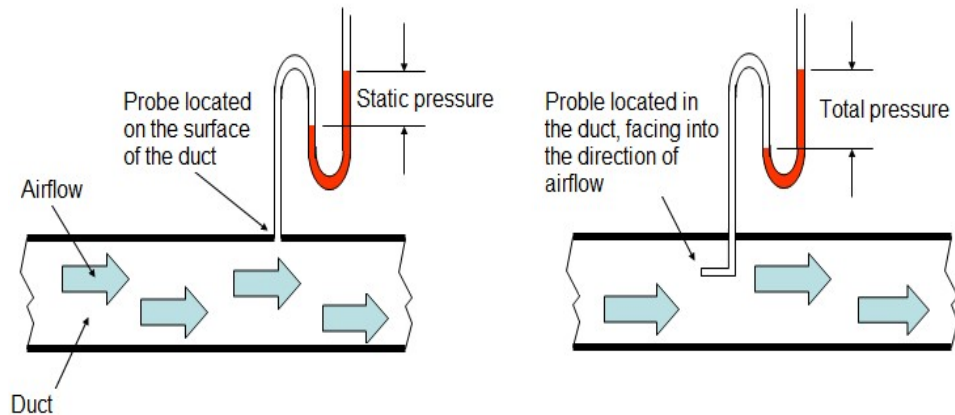

Once you have these two values you can just subtract static pressure from the total pressure and derive the velocity pressure. $VP = TP - SP$

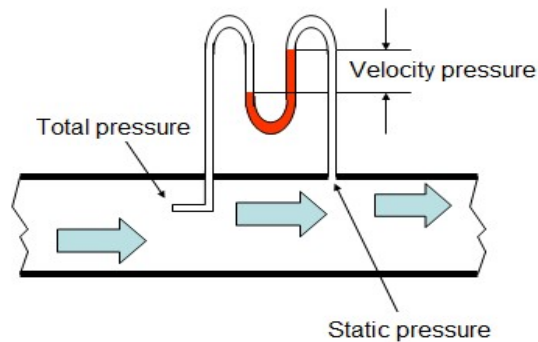

3. Static and velocity pressure are mutually convertible. The magnitude of each is dependent on the local duct cross-section which determines the flow velocity. The following pressure changes are affected in the ducts:
 - **Constant cross-sectional areas:** Total and static losses are equal.
 - **Diverging sections (increase in duct size):** Velocity pressure decreases, total pressure decreases, and static pressure may increase (static regain).
 - **Converging sections (decrease in duct size):** Velocity pressure increases in the direction of flow, total and static pressure decrease.
4. The total pressure generally drops along the air flow because of frictional and turbulence losses.

Confusion in the use of the terms “Static Pressure”, “Velocity Pressure” and “Total Pressure” is widely prevalent among HVAC engineers and contractors. The term “Static Pressure” is typically used for fan selection; “Velocity Pressure” is used for

measuring cfm in a system, and “Total Pressure” is used to find the velocity pressure. Total Pressure determines the actual mechanical energy that must be supplied to the system.

2.0. DUCT COMPONENTS & MATERIALS

The air distribution system will have a designation depending on the function of the duct. Broadly, there are five designations of ducts:

1. Supply air ductwork supplies conditioned air from the air handling unit to the conditioned area.
2. Return air ductwork removes air from the conditioned building spaces and returns the air to the air handling unit, which reconditions the air. In some cases, part of the return air in this ductwork is exhausted to the building exterior.
3. Fresh air ductwork supplies outdoor air to the air handling unit. Outdoor air is used for ventilating the occupied building space.
4. Exhaust (relief) air ductwork carries and discharges air to the outdoors. Exhaust air is taken from toilets, kitchen, laboratories and other areas requiring ventilation.
5. Mixed air ductwork mixes air from the outdoor air and the return air then supplies this mixed air to the air handling unit.

2.1 Duct Components

The figure below shows a schematic and a 3-D representation of supply and return air ductwork. The central air handling unit (AHU) is connected to the air plenum at the starting point. AHU fans draw in air through grilles called returns and force air through the plenum and into the conditioned space through supply registers.

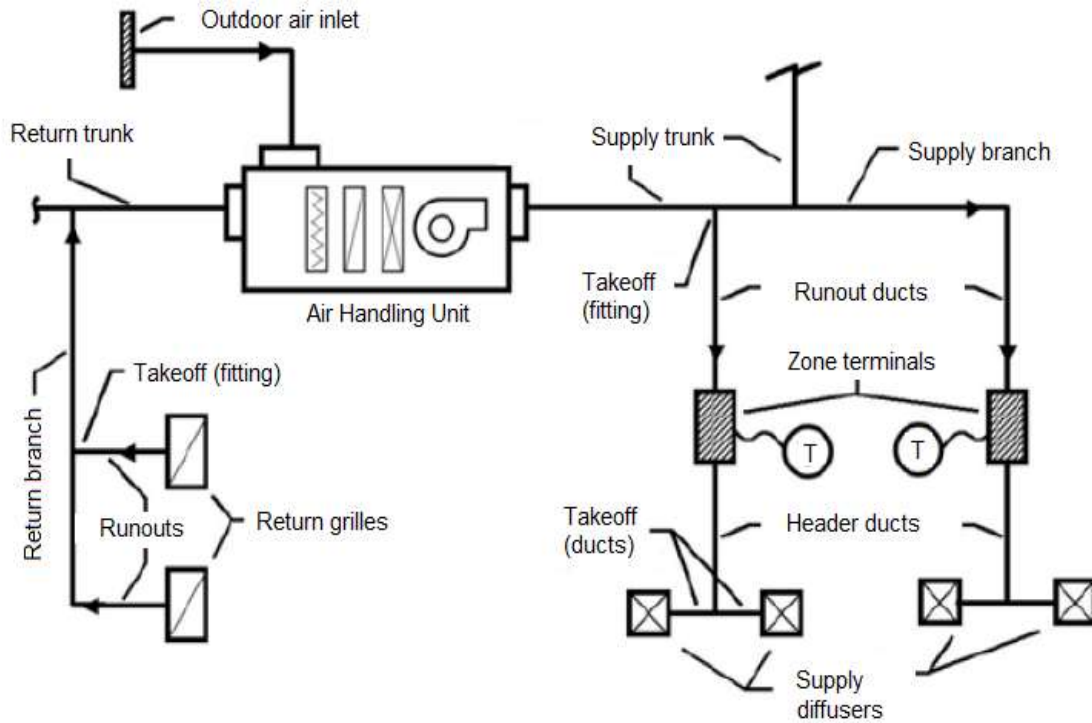

Air conditioning Schematic Drawing

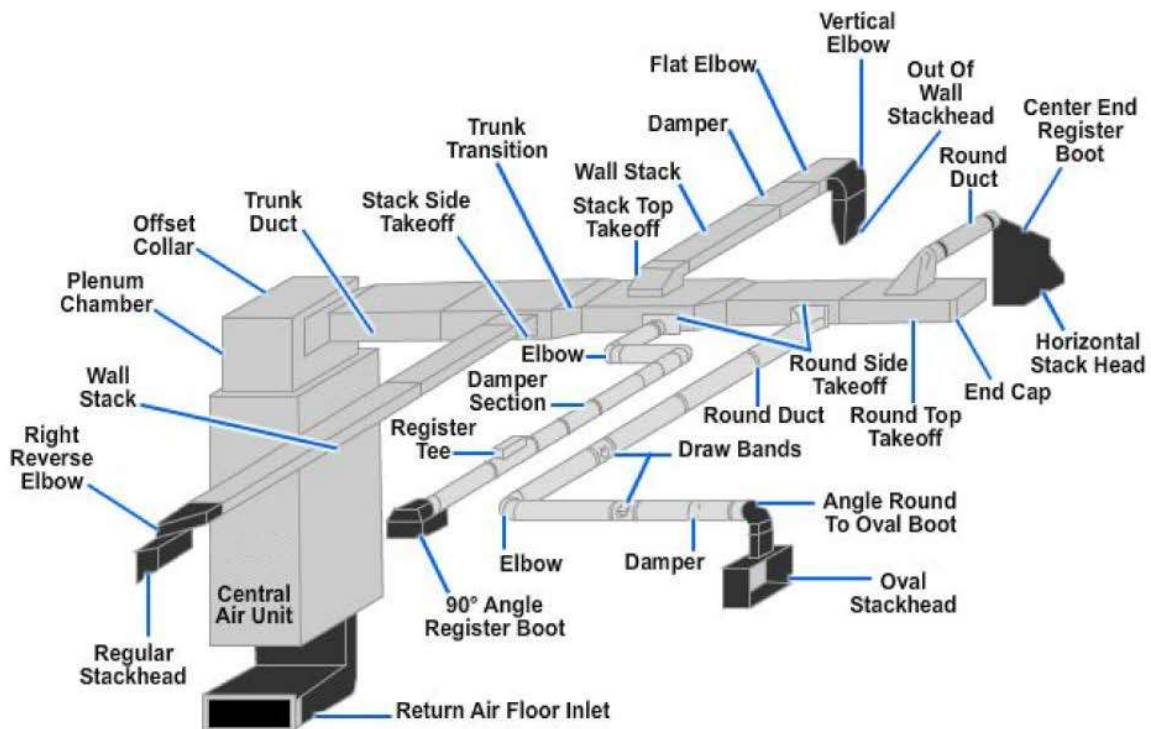

The duct components are as follows:

Plenum or Main Trunk: The plenum is the main part of the supply and return duct system that goes directly from the air handler to the “Trunk Duct”.

Trunk Duct: A duct that is split into more than one duct is called a “trunk”, just like a tree. Ducts that are on the end of a trunk and terminate in a register are called branches.

Take Off: Branch ducts are fastened to the main trunk by a takeoff-fitting. The takeoff encourages the air moving the duct to enter the takeoff to the branch duct.

Air Terminals Devices: Air terminals are the supply air outlets and return or exhaust air inlets. For supply, diffusers are most common, but grilles and registers are also used widely. A diffuser is an outlet device discharging supply air in a direction radially to the axis of entry. A register is a grille equipped with a volume control damper. A grille is without a damper.

2.2 Duct Materials

Ducting is generally formed by folding sheet metal into the desired shape. Traditionally, air conditioning ductwork is made of galvanized steel, next in popularity is aluminum. Other metals used under special circumstances are copper and stainless steel. Metals that are used extensively depend on the application of the duct and are listed below:

1. **Galvanized Steel:** It is a standard, most common material used in fabricating ductwork for most comfort air conditioning systems. The specifications for galvanized steel sheet are ASTM A653, coating G90.
2. **Aluminium:** It is widely used in clean room applications. These are also preferred systems for moisture laden air, special exhaust systems and ornamental duct systems. The specifications for Aluminium sheet are ASTM B209, alloy 1100, 3003 or 5052.
3. **Stainless Steel:** It is used in duct systems for kitchen exhaust, moisture laden air, and fume exhaust. The specifications for stainless steel sheet are ASTM A167, Class 302 or 304, Condition A (annealed) Finish No. 4 for exposed ducts and Finish No. 2B for concealed duct.
4. **Carbon Steel (Black Iron):** It is widely used in applications involving flues, stacks, hoods, other high temperature and special coating requirements for industrial use.
5. **Copper:** It is mainly used for certain chemical exhaust and ornamental ductwork.

Pressure in the air conditioning ducts is small, so materials with a great deal of strength are not needed. The thickness of the material depends on the dimensions of the duct, the length of the individual sections, and the cross-sectional area of the duct.

Non-Metallic ducts

This category includes ducts made from plastic or foam boards, shaped by cutting and folded to produce the required cross-sectional geometry. Boards are faced usually with an aluminum coating, both internal and external.

The main drawback of this type of ducting is its fire classification. Even if it complies with local standards, when exposed to fire, it often exhibits poor performance in terms of the production of both smoke and flaming droplets.

1. **Fibreglass Reinforced Plastic (FRP):** It is used mainly for chemical exhaust, scrubbers, and underground duct systems. Advantages are resistance to corrosion, self-insulation, excellent sound attenuation and high quality sealing. Limiting characteristics include cost, weight, range of chemical and physical properties, and code acceptance.
2. **Polyvinyl Chloride (PVC):** It is used for exhaust systems for chemical fumes and underground duct systems. Advantages include resistance to corrosion, light weight, and ease of modification. Limiting characteristics include cost, fabrication, code acceptance, thermal shock, and weight.
3. **Fabric:** Fabric ducting, also known as textile ducts, is usually made of special permeable polyester material and is normally used where even air distribution is essential. Due to the nature of the air distribution, textile ducts are not usually concealed within false ceilings. Condensation is not a concern with fabric ducts and therefore these can be used where air is to be supplied below the dew point without insulation.
4. **Flex Duct:** Flex ducts consist of a duct inner liner supported on the inside by a helix wire coil and covered by blanket insulation with a flexible vapor barrier jacket on the outside. Flex ducts are often used for runouts, as well as with metal collars used to connect the flexible ducts to supply plenums, trunks and branches constructed from sheet metal or duct board. Flex ducts provide convenience of installation as these can be easily adapted to

avoid clashes but has certain disadvantages. These have more friction loss inside them than metal ducting. Flex duct runs should be as short as possible (5 to 6 ft. max.) and should be stretched as tight as possible.

3.0. DUCT CLASSIFICATION

Ducts are classified in terms of velocity and pressure.

3.1 Velocity Classification

Ducts are classified into 3 basic categories:

1. **Low Velocity Systems:** They are characterized by air velocities up to 2000 fpm.
2. **Medium Velocity Systems:** They are characterized by air velocities in the range of 2,000 to 2,500 fpm.
3. **High Velocity Systems:** They are characterized by air velocities greater than 2,500 fpm.

The low velocity system is used in most air conditioning installations because it is quieter, has lower friction losses, lower fan power, and lower air leakage.

High duct velocities result in lower initial costs but require increased fan static pressures; therefore, resulting in increased operating costs. Often these need additional noise attenuation (use of noise silencers) and are not suitable for comfort applications.

Generally, high-velocity systems are applicable to large multi-story buildings, primarily because the advantage of savings in duct shafts and floor-to-floor heights is more substantial. Small two- and three-story buildings are normally low velocity. A velocity of 1,000 to 1,500 fpm for main ducts and a velocity of 700 to 1,000 fpm for the branch take offs are recommended.

3.2 Pressure Classification

Duct systems are also divided into three pressure classifications, matching the way supply fans are classified.

1. **Low Pressure:** The term low-pressure applies to systems with fan static pressures less than 3 inches WC. Generally, duct velocities are less than 1,500 fpm.

- 2. Medium Pressure:** The term medium pressure applies to systems with fan static pressures between 3 to 6 inches WC. Generally, duct velocities are less than or equal to 2,500 fpm.
- 3. High Pressure:** The term high pressure applies to systems with fan static pressures between 6 to 10 inches WC. Usually the static pressure is limited to a maximum of 7 inches WC, and duct velocities are limited to 4,000 fpm. Systems requiring pressures more than 7 inches WC are normally unwarranted and could result in very high operating costs.

General good engineering practices are:

1. Use of medium pressure classification for primary air ductwork (fan connections, risers, and main distribution ducts).
2. Use of low pressure classification for secondary air ductwork (run-outs/branches from main to terminal boxes and distribution devices).

3.3 Velocity Classification vs. Pressure Classification

1. Duct pressure classification influences the duct strength, deflection and air leakage.
2. Duct velocity classification influences noise, vibration, friction losses and fan power.

4.0. DUCT SHAPES

Ducts commonly used for carrying air are of round, square, or rectangular shape. All have advantages and disadvantages, and find applications where one is definitely superior to the other.

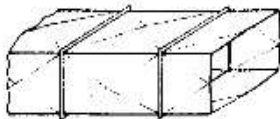

Rectangular Duct



Round Duct

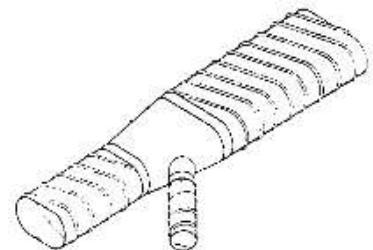

Oval Duct

4.1 Round Ducts

The duct shape that is the most efficient (offers the least resistance) in conveying moving air is a round duct, because it has the greatest cross-sectional area and a minimum contact surface. In other words, it uses less material compared to square or rectangular ducts for the same volume of air handled.

An 18 inch diameter duct, for example, has the same air-carrying capacity as a 26" x 11" rectangular duct. The round duct has a cross-sectional area of 254.5 sq.-in and a perimeter of 4.7 ft., while the rectangular duct has a 286 sq.-in area and a perimeter of 6.2 ft. The rectangular duct thus has 32% more metal in it and would cost proportionately more. Also the insulation, supports and labor are higher for rectangular ducts of similar capacity.

Some of the advantages of round ductwork include:

- Round shape results in lower pressure drops, thereby requiring less fan horsepower to move the air and, consequently, smaller equipment.
- Round shape also has less surface area and requires less insulation when externally wrapped.
- Round ducts are available in longer lengths than rectangular ducts, thereby eliminating costly field joints. Spiral lock-seams add rigidity; therefore, spiral ducts can be fabricated using lighter gauges than longitudinal seam ducts. Spiral ducts leak less and can be more easily sealed compared to rectangular ducts.
- The acoustic performance of round and oval ducts is superior because their curved surfaces allow less breakout noise. The low-frequency sound is well contained in round ducts.
- Round ducts can help promote healthier indoor environments. Less surface area, no corners and better air flow reduce the chance of dirt and grime accumulating inside the duct and, therefore, becoming a breeding ground for bacterial growth.

While round air ducts have great advantages, there are some disadvantages to them. One of the most notable drawbacks of round air ducts is that they need more clear height for installation. If the net clear height of a furred space above a suspended

ceiling is 14 inches, an 18-in diameter duct cannot be installed therein; however, its equivalent 26" x 11" rectangular duct will fit the space easily. A combination of a rectangular plenum and round branches sometimes is a good compromise.

4.2 Rectangular Ducts

Square or rectangular ducts fit better to building construction. They fit above ceilings and into walls, and they are much easier to install between joists and studs.

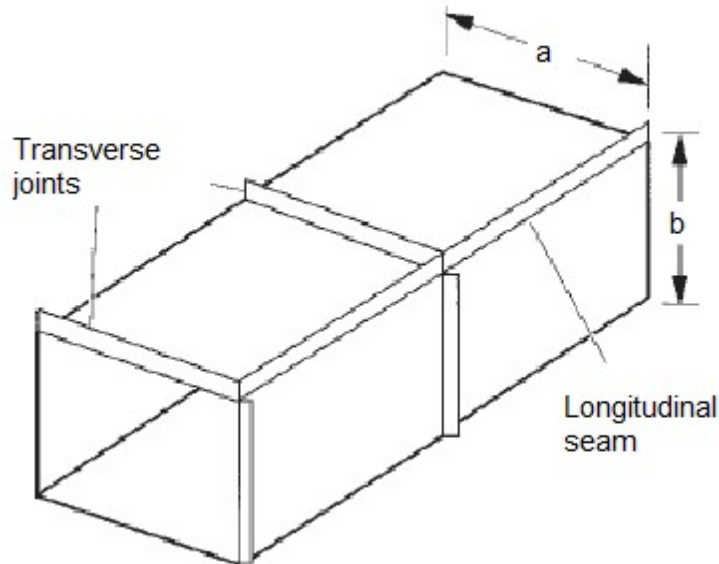

When rectangular ducts must be used due to space limitations, keep the width-to-height ratio (aspect ratio) low. A rectangular duct section with an aspect ratio close to 1 yields the most efficient rectangular duct shape in terms of conveying air. A duct with an aspect ratio above 4 is much less efficient in use of material and experiences great pressure losses. Aspect ratios of 2 to 3 are ideal in trading off added duct cost of material and fan energy for headroom savings.

Disadvantages of rectangular ducts are as follows:

1. They create higher pressure drop;
2. They use more pounds of metal for the same air-flow rate as round ducts;
3. Their joint length is limited to the sheet widths stocked by the contractor;
4. Their joints are more difficult to seal;

5. Those with high aspect ratio can transmit excessive noise if not properly supported.

4.3 Oval Ducts

Flat oval ducts have smaller height requirements than round ducts and retain most of the advantages of the round ducts. However, fittings for flat oval ducts are difficult to fabricate or modify in the field. Other disadvantages include:

1. Difficulty of handling and shipping larger sizes;
2. Tendency of these ducts to become more round under pressure; and,
3. In large aspect ratios, difficulties of assembling oval slip joints.

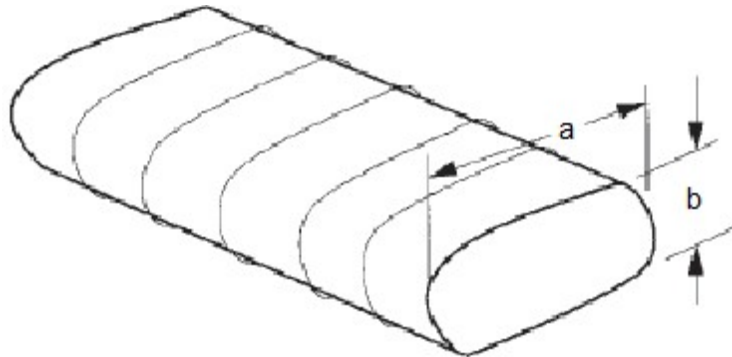

4.4 Equivalent Diameter

Since both round and rectangular ducts are extensively used in air conditioning systems, it is quite possible that a contractor may wish to substitute one for the other while working on new construction or modifying an existing system. With this likelihood, there is the general tendency to substitute cross-sectional areas of round and rectangular ducts. This is improper and will affect air distribution system performance. Therefore, it is necessary for the HVAC designer to fully understand the conditions under which round and rectangular ducts can be interchanged. The important thing is the duct pressure drop and that's where the concept of "equivalent diameter" comes into picture.

By definition, equivalent diameter (D_{eq}) is the diameter of a circular duct that will give the same pressure drop at the same air flow as the rectangular duct.

From ASHRAE Fundamentals Handbook, the following equations may be used to convert rectangular and flat oval ducts to and from round.

$$\text{Rectangular ducts: } D_{\text{eq}} = \frac{1.30 (ab)^{0.625}}{(a+b)^{0.250}}$$

$$\text{Flat oval ducts : } D_{\text{eq}} = \frac{1.55 A^{0.625}}{p^{0.250}}$$

$$A = \frac{\pi b^2}{4} + b(a - b)$$

$$p = \pi b + 2(a - b)$$

where,

- p = perimeter of oval duct (in.)
- A = cross-sectional area (sq.-in)
- a = length of major axis (in.)
- b = length of minor axis (in.)

Equivalent Diameter vs. Equivalent Cross-sectional Area Approach

Consider an air flow rate of 7,500 cfm and compare a 30” diameter round duct to equivalent rectangular and oval duct options.

Equivalent Diameter Approach

For a given round duct diameter (30 inches), the dimensions for rectangular and flat oval ducts must be solved for by trial and error. Fix one dimension and substitute in the equations above. Let’s use 16 inches for the minor axis, then the equivalent rectangular duct dimension will be 16”X 51”, and flat oval ducts with a 16-in. minor axis will be 16” X 53”.

What this means is that all three ducts, 30” round, 16” x 51” rectangular, and 16” x 53” flat oval will have the same friction loss for a given cfm. The table below summarizes the equivalent diameter approach.

Duct shape	Exact converted dimensions (inches)	Rounded dimensions	Cross sectional area (sq.-ft.)	Velocity (fpm)	Friction loss (in.-WC/100ft)
Round		30	4.91	1528	0.10
Flat oval	16 x 52.5	16 x 53	5.51	1361	0.10
Rectangular	16 x 51	16 x 51	5.67	1362	0.10

From the analysis above, all three ducts have the same friction loss factors because they are equivalent (in terms of pressure drop per unit length). Note that the cross-sectional areas of the rectangular and oval ducts will always be larger than that of the round duct with the same equivalent diameter.

Equivalent Cross-sectional Area Approach

Let's see what happens when using an equivalent cross-sectional area approach.

Diameter of duct = 30 inches or 2.5 ft.

Cross-sectional area of the 30-inch diameter duct = $3.14 * 2.5 * 2.5/4 = 4.91$ sq.-ft.

Cross-section area of rectangular duct:

$$A = a * b$$

Fixing minor axis "b" as 16 inches;

Major axis "a" will be = $4.91 * 144/16 = 44.2$ inches.

Cross-sectional area of oval duct:

$$A = \frac{\pi b^2}{4} + b(a - b)$$

Fixing minor axis "b" as 16 inches;

Major axis "a" will be = 47.6 inches.

Velocity in the duct

Velocity in duct can be expressed as:

$$v = Q / A$$

where,

- v = air velocity in feet per minute, (fpm)
- Q = air flow through duct in cubic feet per minute, (cfm)
- A = cross-section of duct in square feet, (sq.-ft.)

Friction loss is estimated from the duct friction charts for a given air flow rate and velocity (refer to the “duct sizing” section below for details).

The table below summarizes the equivalent cross-sectional area approach.

Duct shape	Air flow, (Q) cfm	Exact converted dimensions (inches)	Rounded dimensions	Cross sectional area (A) sq.-ft.	Velocity (v) fpm $v = Q/A$	Friction loss (in.-WC/100ft)
Round	7500		30	4.91	1528	0.10
Flat oval	7500	16 x 47.6	16 x 48	4.95	1514	0.12
Rectangular	7500	16 x 44.2	16 x 44	4.89	1534	0.14

You can see the frictional loss increases with increasing velocity and lower cross-sectional area.

In Conclusion

The equivalent diameter approach will retain the same pressure drop but will result in higher cross-sections of rectangular and oval ducts compared to round ducts.

The equivalent area approach will increase the pressure drop of the duct run while keeping the cross-sectional area the same.

5.0. DUCT SIZING

The most widely used method to size ducting is the equal friction method. The other methods are velocity reduction and static regain.

5.1 Equal friction method

The Equal Friction design method sizes the ducts for a constant “Friction Rate”, which describes the average pressure drop per 100 feet of duct in a system. A

very common friction rate for a reasonably well designed system is 0.1 in.-wc per 100 ft. of duct length. Reduced friction rates of 0.05 in.-wc per 100 ft. increases the duct size and costs by 15%, but cuts the portion of the total pressure drop in ductwork by 50%, resulting in fan energy savings of 15% to 20%.

Procedure:

Equal friction method uses a duct slide rule, duct calculator, or friction rate chart to determine the relationship between duct size and air flow, i.e. how much air will come out of a given size duct. The methodology is as follows:

- a. Select maximum air velocity in main duct after fan outlet.
- b. Enter the friction chart knowing the cfm and velocity to determine the friction rate per 100 feet of duct length and select the diameter (refer to chart below).
- c. From the friction rate obtained in the previous step, use the same value to determine diameters for all other sections of the ductwork.
- d. The total friction loss in the duct system is then calculated by multiplying the friction loss per 100-foot of length to the equivalent length of the most critical path of the ductwork having maximum resistance.

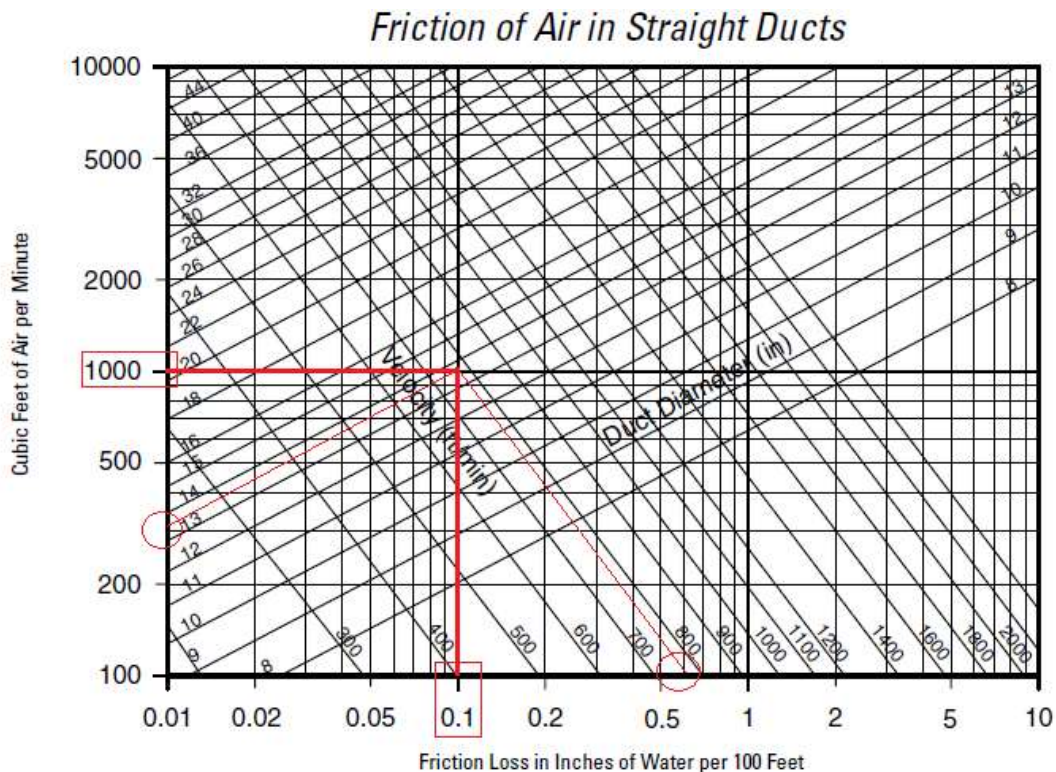

Example

Determine the diameter and the velocity of air through a duct carrying 1,000 cfm of air. Assume a friction loss of 0.1 in.-wc per 100 ft. of duct length. Determine the real pressure drop and velocity on the selected duct size.

Solution:

From the above monograph, the 0.1 in.-wc per 100 ft. friction line intersects the 1,000 cfm line at a round duct diameter of 13.5 inch. Select the next available round duct size of 14". When this duct is used, the pressure loss will be 0.09 in.-wc/100', and the velocity is ~800 fpm. *(Note: the chart illustrated above is only for educational purpose and may be out of scale.)*

There are a variety of commercially available duct calculator tools (also known as ductulators) that are easy and accurate to use for sizing ducts if you know the flow rate and friction loss or velocity. Use the following friction loss guidelines for sizing ducts with a duct calculator tool.

System Type	Friction Loss per 100 Feet of Duct (inch water column)
Supply run-outs	0.08
Supply trunk or plenum	0.05
Return ducts	0.02

Advantages of the Equal Friction Method:

1. The method is straightforward and simple.
2. It automatically reduces air velocities in the direction of air flow, which in turn reduces the potential air flow generated noise.
3. It is the most appropriate method for constant air volume (CAV) systems.

Limitations of the Equal Friction Method:

1. There is no equalization of pressure drops in duct branches unless the system has a symmetrical layout. Balancing dampers must be installed to balance the system.

2. It is not recommended for VAV systems. If used for VAV supply duct design, the terminal units require pressure independent (Pi) control capability to avoid excessive flow rates when duct pressure is high.
3. It is not flexible and adaptable to future layout changes.

5.2 Velocity Reduction Method

This method sizes the duct by varying the velocity in the main and branch ducts. The various steps involved are:

- a. Select suitable velocities in the main and branch ducts. The table below indicates commonly used velocity limits:

Type of Duct	Comfort Systems Velocity (fpm)	Industrial Systems Velocity (fpm)	High Speed Systems Velocity (fpm)
Main duct	1000 - 1500	1500 - 2400	2000 - 3600
Main branch duct	700 - 1000	1000 - 1600	1200 - 2400
Runout duct	400 - 600	600 - 800	800 - 1000

- b. Find the diameters of the main and branch ducts from air flow rates and velocities. The velocity in duct can be expressed as:

$$A = Q / v$$

Where,

- A = duct area (ft²)
 - Q = air flow rate (cfm)
 - v = air speed (fpm)
- c. From the velocities and duct dimensions obtained in the previous step, find the frictional pressure drop for the main and branch ducts using the friction chart above.

5.3 Static Regain Method

Static regain is the process of converting velocity pressure (VP) to static pressure (SP). We learnt in previous sections that the total pressure (TP) in a duct system is equal to the sum of the static pressure and velocity pressure ($TP = SP + VP$). Therefore, for a given TP, if the VP is high (usually because the duct area is small), then the static pressure (SP) must be low. SP is the pressure that causes the air in the duct to flow, and VP is the pressure that results from the air movement. This means that it is desirable to have a high value of static pressure (SP) compared to the total pressure (TP) developed by the fan.

The Static Regain method of duct sizing is based on Bernoulli's equation, which states that when a reduction of velocities takes place, a conversion of velocity pressure into static pressure occurs. With this method, the duct velocities are systematically reduced over the length of the distribution layout, which allows the velocity pressure to convert to static pressure, offsetting friction losses in the succeeding section of duct. This means there is the same static pressure near all the branches and all the diffusers and, therefore, the system design requires little or no balancing.

Advantages:

1. All duct sections have uniform static pressure at all branches and outlets, thereby simplifying outlet selection and correct air quantity at each outlet.
2. The duct system will stay in balance because the losses and gains are proportional to a function of the velocities. Therefore, it is an excellent method for designing variable air volume systems.
3. The Static Regain method uses less pounds of sheet metal and is less noisy.

Disadvantages:

1. One disadvantage might be seen in networks with a large pressure drop in a section near the fan outlet. The velocity could be reduced to the minimum within a few sections in such a way that all the ductwork downstream would be sized using minimum velocity.
2. Another disadvantage could stem from specifying a very low minimum velocity. Ducts would then tend to be very large at the end of long branch runs. The sizing method does not account for the total mechanical energy

supplied to the air by the fan. Oversized ducts can occur at the ends of long branches.

6.0. PRESSURE LOSSES IN AIR DISTRIBUTION SYSTEM

The system resistance in ductwork has three components:

1. Friction loss (resistance to air flow caused by duct size, roughness of duct walls, and air velocity).
2. Dynamic loss (resistance to air flow caused by changes in air velocity and direction).
3. Equipment pressure loss (resistance to air flow caused by components such as diffusers, coils, and filters).

6.1 Duct Friction Losses

Any type of duct system offers frictional resistance to the movement of air. Resistance to air flow produces certain friction losses that vary with:

- a. Velocity of air
- b. Size of duct (smaller diameter duct has more friction)
- c. Roughness of the material
- d. Length of the duct

The frictional resistance of a supply duct varies in proportion to the square of the ratio of the velocity, and the fan power varies as the cube of this ratio. For example, if a supply duct is carrying 5,000 cfm of air at 1000 fpm, and a second smaller supply duct is carrying 5,000 cfm of air at 2,000 fpm, the frictional resistance of the second duct per foot of duct length will be **four** times higher than that of the first duct: $(2,000/1,000)^2$; and the power required to overcome this frictional resistance will be **eight** times as much: $(2,000/1,000)^3$.

The easiest way of estimating frictional loss per unit length is by using the monograph below.

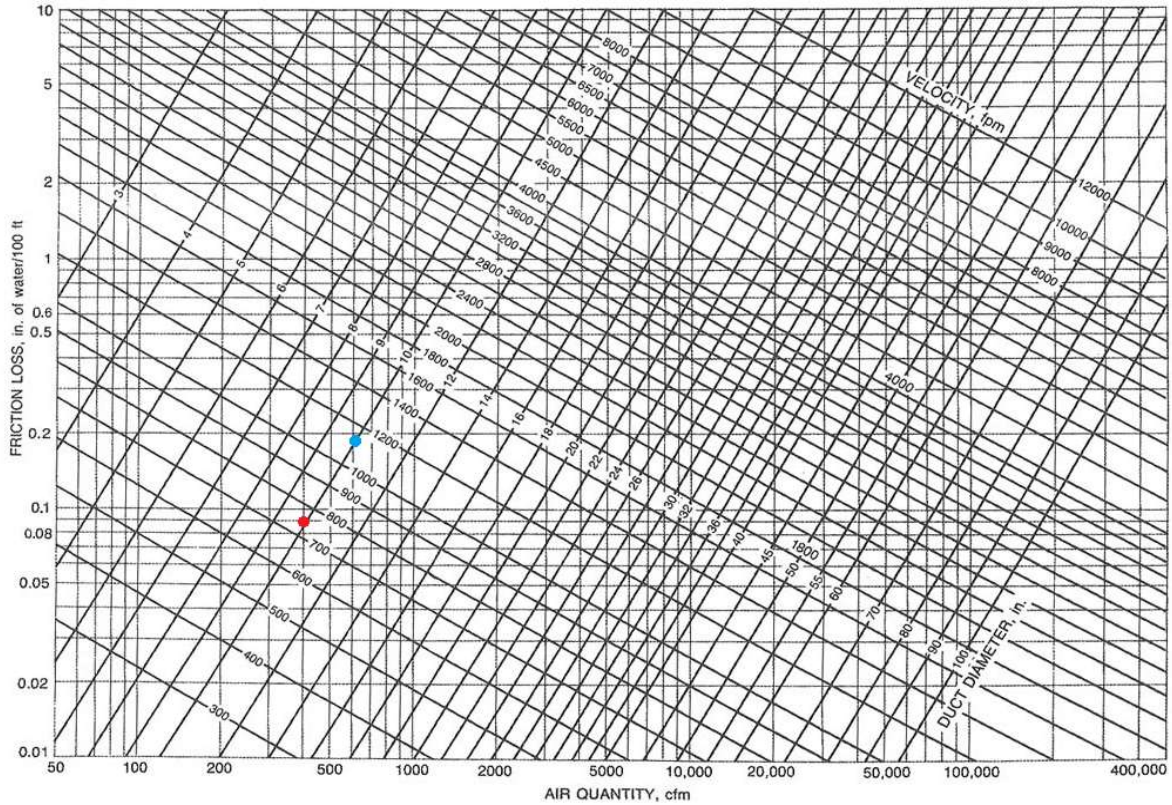

Example (use of friction loss chart):

A 100 ft. length of a 10 inch dia. duct carrying 400 cfm would have a friction loss of 0.09 inches of water column.

A 100 ft. length of a 10 inch dia. duct carrying 600 cfm would have a friction loss of approximately 0.2 inches of water column.

A 200 ft. length of a 10 inch dia. duct carrying 600 cfm would have a friction loss of approximately 0.4 inches of water column. $[200/100] \times 0.2 = 0.4$ in.-wc.

Problem:

Calculate the friction head loss (in-H₂O) from moving 20,000 cfm of air through 200 feet of a 34-inch diameter duct.

Solution:

From the monograph, the friction loss at 20,000 cfm in a 34-inch duct is 0.3 in-WC per 100 ft. of duct.

Therefore the Total loss = Friction Loss x Length = $[0.3 \text{ in-WC per } 100\text{-ft duct}] \times 200 \text{ ft. of duct} = 0.6 \text{ in-WC}$

Mathematical Equation for Duct Pressure Loss

Mathematically, the Darcy Weisbach equation may be used to determine the pressure drop in ducts.

$$\Delta P \left[\frac{lb}{ft^2} \right] = f * \rho \left[\frac{lb}{ft^3} \right] * \frac{L[ft]}{D[ft]} * \frac{V^2 \left[\frac{ft}{s} \right]}{2g \left[\frac{ft}{s^2} \right]}$$

Converting to more commonly used HVAC and Refrigeration units:

$$\Delta P[in. wg] = f * \frac{12 * L[ft]}{D[in]} * \rho \left[\frac{lb}{ft^3} \right] \left(\frac{V \left[\frac{ft}{min} \right]}{1097} \right)^2$$

where,

- P = Pressure drop, in. of water
- f = Friction factor, dimensionless
- L = Duct length, ft
- D = Internal diameter of duct in inches (convert to equivalent diameter for non-circular duct)
- V = Velocity, fpm
- ρ = Density, lb_m/ft³

6.2 Duct Fitting Dynamic Losses

Dynamic losses in duct systems are pressure losses caused by:

- The change in air direction from elbows, offsets, and take-offs.
- Restrictions or obstructions in the air stream such as dampers, filters, and coils.
- Changes in air velocity because of changes in duct size.

Methods of computing the energy losses from the various fitting types are based on information found in ASHRAE Handbook of Fundamentals or can be calculated from loss-coefficient charts developed by the Sheet Metal and Air Conditioning National Contractors' Association (SMACNA).

The total pressure loss from friction through the fittings, F_{fitting} , is proportional to the velocity pressure (VP). The constant of proportionality depends on the fitting. Thus, the total pressure loss from friction through a fitting is calculated as:

$$F_{\text{fitting}} = K * VP$$

$$F_{\text{fitting}} = K \left(\frac{V}{4005} \right)^2$$

The dynamic loss coefficient (K) is measured empirically and reported by the fitting manufacturers. Often for simplicity, an “equivalent length” method is used wherein a type of fitting such as a T-wye or elbow is assigned a number that represents a length of straight duct that has an equal pressure drop. For example a T-wye might have an equivalent length of 10 feet. A ninety degree elbow might have an equivalent length of 15 feet. A round start collar coming off of a sheet metal supply plenum can have equivalent lengths approaching 30 feet or more. This additional length is then added to the straight length of the duct to get the overall effective length.

6.3 The Concept of Duct Equivalent Length

Equivalent length refers to the number of feet of straight duct that imposes the same resistance to the air flow as a particular fitting. Suppose we have a blower duct set up as shown in the figure below, and we can measure the static pressure before (P_1) and after (P_2), the elbow. In addition, we have a third gauge (P_3) which we can locate anywhere along the length of the duct. Let’s say the duct system is made up of 7-inch round pipe, including the elbow.

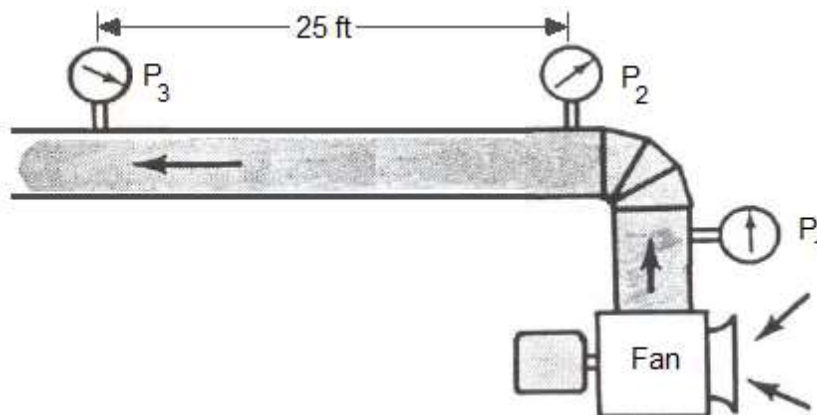

With 250 cfm flowing through the system, we would find that the pressure loss of the elbow, or the difference between gauge readings P_1 and P_2 would be about 0.054 inches WG. Now to obtain the same pressure loss through the run of straight pipe between gauges P_2 and P_3 , we would find that gauge P_3 must be placed 25 feet away from gauge P_2 before the losses were the same. Thus, for the condition stated, the pressure loss of the 7-inch round elbow is equivalent to the loss of 25 ft. of 7-inch round duct.

If we increase the air flow rate through the system we would find that to keep the readings between gauges equal, we would have to move gauge P_3 further away from gauge P_2 . In other words, if we increase the flow rate to say 350 cfm, gauge P_3 might have to be placed 26 or 27 ft. away from P_2 to obtain the same loss reading as experienced by the elbow. Conversely, if we lower the flow rate, the distance between P_2 and P_3 could be narrowed.

A fitting's pressure loss thus can be conveniently expressed in terms of equivalent length of straight duct of any size. Equivalent lengths are numbers that can be looked up in an appendix of ACCA Manual D, ASHRAE or SMACNA guides.

Note that the equivalent length of a fitting is different from the effective length, which is the sum of the actual measured length of a duct plus all the equivalent lengths of the various fittings.

6.4 Pressure Loss across Components

The air handler is the single greatest pressure drop item in the ductwork. Components in the air handling unit such as filters or coils have a definite static pressure drop across them based on the air flow. For example, a "dry" coil may have a static pressure drop of 0.45 inch water column at 550 fpm. A "wet" coil, which is a water coil operating with condensate on the fins, would have a higher drop at the same velocity. Another example of changing pressures would be a filter having a certain static pressure drop when clean, and a higher drop when dirty. To reduce the pressure drop, specify a low face velocity unit in the 250 to 450 fpm range. The fan power requirement decreases approximately as the square of the velocity decrease.

7.0. FAN SIZING

In a duct system, a fan is used to supply the necessary forces to bring the fluid from rest to the system velocity, and overcome friction forces. The force exerted by the fan

is the fan total pressure. The total pressure is divided into two vector components. The first component, velocity pressure, is in the direction of the flow and whose magnitude is positive and proportional to the velocity. The second component, static pressure, is normal to the direction of the flow. Static pressure may be positive, exerting outward from the frame of reference, or negative, exerting inward. Velocity pressure is always positive, and the sum of the static and velocity pressures is the total pressure.

7.1 Fan Selection Example

The fan must be selected to deliver a specific volumetric flow rate (cfm) and generate static pressure (in – H₂O) to overcome the pressure losses due to ducts, fitting, and the components of an air handling unit (AHU). The total static pressure (TSP) is the sum of the external static pressure (ESP) and internal static pressure (ISP).

$$\text{TSP} = \text{ESP} + \text{ISP}$$

where,

- ESP is the static pressure created downstream of the AHU and it includes all the duct losses from the fan until it reaches the discharge point. This could include a negative static pressure on the pull side of the fan and a positive pressure on the push side, or any combination of pressures the fan must overcome. It is estimated by the HVAC design engineer as he lays out the ductwork, diffusers, and terminal devices.
- ISP, as it pertains to the HVAC AHU, is the static pressure loss across the filters, coils, louvers, dampers, and twists and turns inside the AHU casing. ISP is usually provided by the supplier, but for custom designs, the HVAC design engineer estimates the pressure loss across the various components of the AHU.

Below is a simple model to calculate the total pressure loss (using the equal friction method) and the selection of fan.

Example

An air conditioning layout below depicts an air handling unit (AHU) supplying cool air to an office space. The supply air fan discharges to supply air diffusers SAD -1 & SAD - 2 through the supply duct and draws air through the return duct via the return air grille (RAG -1). It also draws fresh air through a louver (OAL -1). Estimate the total pressure loss for sizing the fan.

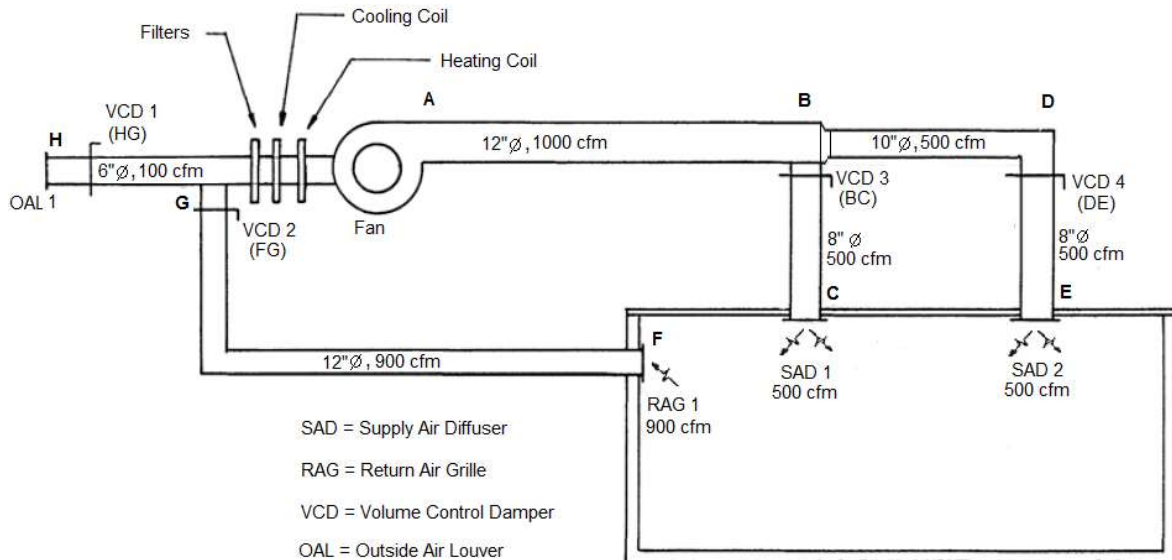

Solution:

The layout shows four (4) paths of air flow and six (6) duct sections.

Path #1: Air supply through duct sections AB and BC

Path #2: Air supply through duct sections AB, BD and DE

Path #3: Air return through duct section FG

Path #4: Outdoor air intake through duct section HG

The section occurs at:

- Change in duct size
- Change in air volume

Now using the friction charts, let's find out the duct pressure losses per 100-ft. length of duct.

Path #1:

- Duct run AB; (12" diameter, 1000 cfm) = 0.2 in.-wc/100 ft. duct length
- Duct run BC ; (8" diameter, 500 cfm) = 0.37 in.-wc/100 ft. duct length
- SAD-1 = 0.12 in.-wc (from manufacturer's catalog)
- Total Pressure Loss = [0.2 + 0.37 + 0.12] = 0.69 in.-wc/100 ft. of duct length

Path #2:

- a. Duct run AB; (12" diameter, 1000 cfm) = 0.2 in.-wc/100 ft. duct length
- b. Duct run BD ; (10" diameter, 500 cfm) = 0.14 in.- wc/100 ft. duct length
- c. Duct run DE; (8" diameter, 500 cfm) = 0.37 in.-wc/100 ft. duct length
- d. SAD-2 = 0.12 in. -wc (from manufacturer's catalog)
- e. Total Pressure Loss = $[0.2 + 0.14 + 0.37 + 0.12] = 0.83$ in.-wc/100 ft. duct length

Path #3:

- a. RAG -1 = 0.08 in.- wc (from manufacturer's catalog)
- b. Duct runs FG; (12" diameter, 900 cfm) = 0.16 in.-wc/100 ft. duct length
- c. Total Pressure Loss = $[0.08 + 0.16] = 0.24$ in. – wc/100 ft. duct length

Path #4:

- a. OAL-1 = 0.08 in. - wc (from manufacturer's catalog)
- b. Duct runs HG; (6" diameter, 100 cfm) = 0.08 in.-wc/100 ft. duct length
- c. Total Pressure Loss = $[0.08 + 0.08] = 0.16$ in.-wc/100 ft. duct length

Pressure Loss due to Fittings

All the pressure losses computed above are for 100-ft. length of duct. Pressure drops in duct fittings have equivalent lengths. All duct lengths and equivalent lengths are added together to achieve the maximum ESP. Say, for this example, the effective length (straight length of duct + equivalent length of fittings) for various duct sections is:

- a. AB = 25 ft.
- b. BC = 35 ft.
- c. BD = 75 ft.
- d. DE = 35 ft.
- e. FG = 50 ft.
- f. HG = 10 ft.

Let's compute the total pressure losses on actual lengths.

Path #1:

- a. Duct run AB = $0.2 \times 25/100 = 0.05$ in. - wc
- b. Duct run BC = $0.37 \times 35/100 = 0.13$ in.- wc
- c. SAD-1 = 0.12 in.- wc
- d. Total Pressure Loss = $[0.05 + 0.13 + 0.12] = 0.30$ in.- wc

Path #2:

- a. Duct run AB= $0.2 \times 25/100 = 0.05$ in.- wc
- b. Duct run BD = $0.14 \times 75/100 = 0.10$ in.- wc
- c. Duct run DE = $0.37 \times 35/100 = 0.13$ in.- wc
- d. SAD-2 = 0.12 in. - wc
- e. Total Pressure Loss = $[0.05 + 0.10 + 0.13 + 0.12] = 0.40$ in.- wc

Path #3:

- a. RAG -1 = 0.08 in.- wc
- b. Duct runs FG= $0.16 \times 50/100 = 0.08$ in.- wc
- c. Total Pressure Loss = $[0.08 + 0.08] = 0.16$ in. - wc

Path #4:

- a. OAL-1 = 0.08 in. - wc
- b. Duct runs HG = $0.08 \times 10/100 = 0.008$ in.- wc
- c. Total Pressure Loss = $[0.08 + 0.008] = 0.09$ in.- wc

Maximum ESP:

Sum the pressure losses calculated for each branch from the fan to an air discharge point. The branch with the largest pressure loss sets the system pressure drop. In our example, it is Path #2 + Path #3 give the maximum pressure loss.

$$ESP_{\max} = 0.40 + 0.16 = 0.56 \text{ in.-wc}$$

Equipment Loss (ISP):

- a. Filters = 0.15 in.- wc (from manufacturer's catalog)
- b. Cooling Coil = 0.50 in.- wc (from manufacturer's catalog)

- c. Heating Coil = 0.28 in. - wc (from manufacturer's catalog)

Maximum ISP:

Maximum ISP is the sum of component losses.

$$ISP_{\max} = 0.15 + 0.50 + 0.28 = 0.93 \text{ in.-wc}$$

Fan Selection:

The fan selection shall be made based on the total pressure loss.

$$SP_{\max} = ESP_{\max} + ISP_{\max}$$

$$SP_{\max} = 0.56 + 0.93 = 1.49 \text{ in.-wc}$$

Safety factor, (SF-1)

To allow for the accumulation of dirt on the filters and coils, and for possible changes in the installation of duct work, a safety factor (10 to 15%) is usually added.

Safety factor, (SF -2)

The configuration of the fan connection to the duct at the inlet and outlet causes serious degradation to the fan performance and is usually compensated by putting some additional safety factor. This is called “fan system effect factor” and the value is based on the use of charts and graphs published by the Air Movement and Control Association (AMCA) and the Sheet Metal and Air Conditioning Contractors' National Association (SMACNA). Alternatively, as a rule of thumb, a 10% safety factor is recommended for system effect. Therefore, the:

$$\text{Total Fan Static Requirement} = SP_{\max} \times SF-1 \times SF-2 = 1.49 \times 1.15 \times 1.1 = 1.9 \text{ in.-wc}$$

Therefore, the fan must be selected to produce a pressure rise of at least 1.9 in.-wc to overcome the ductwork system losses.

Fan Rating

Fan manufacturers usually publish characteristic curves in terms of the fan's static pressure rather than the fan's total pressure. This is understandable as manufacturers may not have control over the types of inlet and outlet duct fittings or the conditions at the entry or exit to the inlet/outlet cones.

7.2 Balancing Air

An important ductwork design consideration is the pressure balance of the duct layout. Actual air flow can exceed design flow if the fan pressure is higher than the pressure loss. In this case, it takes partial closure of the balancing dampers, which control the air flow, to get the air flow rate down to what the duct equipment was designed to handle.

Air balancing is an act of adjusting the volume control dampers to equalize the friction losses. One of the major drawbacks of the equal friction duct sizing method is that there is no equalization of pressure drops in duct branches, unless the system has a symmetrical layout.

In the example above, because air will flow to the path of least resistance, it will be necessary to adjust the balancing damper in line BC in order to divide the supply air equally (i.e. 500 cfm per outlet). The ductwork has been installed so that the air path from the fan discharge to SAD-2 has a total resistance of 0.40 in.-wc; whereas, the resistance to air flow from the fan to SAD -1 is only 0.30 in .wc.

This means that SAD-1 will tend to get more air than is required and SAD-2 will receive less than the design cfm. To balance the air in each duct line, damper BC will be adjusted so that it will impose a resistance in line BC equal to 0.10 in.wc, which is the calculated difference in pressure loss between the two duct runs (0.4 -0.3).

As with the supply runs, the return and outside duct runs have different pressure losses. Therefore, in order to balance the return and outside duct lines, the outside air damper HG will be adjusted so that it imposes a resistance of 0.07 in.-wc (the difference between the return run and the outside air (0.09 -0.16).

7.3 Fan System Effect

Typically the fan performance curves are developed by laboratory measurements with the fan installed under ideal conditions. However, when the duct system is connected to the fan, the fan operating conditions are influenced and the fan performance will get altered. The figure below shows the air velocity profiles in a duct at various distances from the outlet of a housed centrifugal fan. The air in the fan is pushed against the outside of the housing by the movement of the fan wheel. Therefore, at the fan outlet, there is a high velocity at the top of the fan outlet. However, at the bottom of the fan outlet there is a negative velocity, because the air is swirling back to the fan at the cut-off plate, attempting to re-enter the fan.

At point A in the figure, the velocity pressure is high and the available static pressure is low. As the air moves down the duct, the velocity of the air becomes more uniform across the duct, and the static pressure increases as the velocity pressure decreases. At point B in the figure, the air velocity is uniform across the duct, and low compared to the outlet velocity (point A).

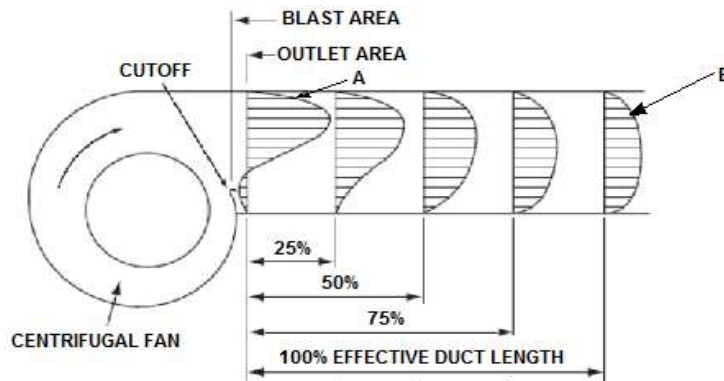

Fan outlet velocity profile

Remember that total pressure is the sum of the velocity pressure and the static pressure. The total pressure in the duct at point B is about the same as it was at point A; therefore, as the velocity pressure has decreased, the static pressure has increased. In other words, the system has gained static pressure. This is static regain. The system now has more potential to overcome the resistance in the system and, thus, the system can deliver more air. At point B, the air velocity is uniform across the duct area and has slowed. This is the point of highest static regain. Duct takeoffs and turns or elbows should be avoided prior to point B because air flow in ducts attached prior to point B will have significant system effect losses that must be accounted for in the sizing of the duct and fan. The distance from A to B is called the 100% effective duct length. The housed fan outlet should be designed with straight duct for the 100% effective duct length, and fittings should not be put near the fan outlet, in order to eliminate system effect at the outlet.

To achieve 100% effective duct length, a straight run from the blower, has to be long enough to achieve a uniform Velocity across the cross-section of the duct. Calculating the 100% effective duct length depends upon the air velocity at the fan outlet:

a. If the outlet velocity is less than 2,500 fpm:

100% effective duct length = 2.5 x duct diameter

b. If the outlet velocity is more than 2,500 fpm:

100% effective duct length = fpm/1000 x duct diameter

c. To calculate the duct diameter:

$D = 2wh / (w + h)$, where h and w are duct height and width, respectively.

Causes of System Effect

The four most common causes of system effect on the fan are:

1. Uneven air flow into the fan inlet
2. Spinning air at the fan inlet
3. Obstructions at the fan inlet or outlet
4. Improper duct connections at the fan outlet or inlet

Fan System Effect Corrections at Design

1. Use of the “**six-and-three rule**” minimizes system loss. Provide six diameters of straight duct at the fan suction and three diameters of straight duct at the fan discharge.
2. Use as long a straight duct as possible for the job conditions. The first elbow in the ducting leaving the unit should be no closer than 2 feet from the unit to minimize resistance and noise.
3. AMCA Standard 210 specifies an outlet duct that is not greater than 107.5 percent or less than 87.5 percent of the fan outlet area.
4. If a duct transition must be used, slant the sides as gradually as possible. AMCA Standard 210 requires that the slope of the transition should not be greater than 15 percent for converging transitions, or greater than 7 percent for diverging transitions.
5. For maximum performance, the air should enter straight into the fan inlet, with a uniform velocity across the area of the inlet. The ideal inlet connection is a long, straight duct with a length four times the diameter of the inlet. If an elbow

is required, there should be a length of straight duct between the fan inlet and the elbow at least two times the diameter of the fan inlet.

6. If a free inlet is required, the inlet duct can be replaced with an inlet bell which provides a smooth transition to the fan velocity with no loss in total pressure.
7. A straight duct for a distance of three to six duct diameters from the fan discharge should be used in order to develop a full dynamic head. Branching and turning sooner causes system effect losses.

8.0. THE SUPPLY DUCT SYSTEM

The two most common supply duct systems are the 'extended plenum' system and the 'radial' system. The other options are spider and perimeter loop systems.

8.1 Extended Plenum Systems

In the extended plenum systems, a large main supply trunk of equal size is connected directly to the air handler. Smaller branch ducts and run-outs are connected to the trunk. The arrangement provides air flows that are easily balanced and can be easily designed to be located inside the conditioned space of the building.

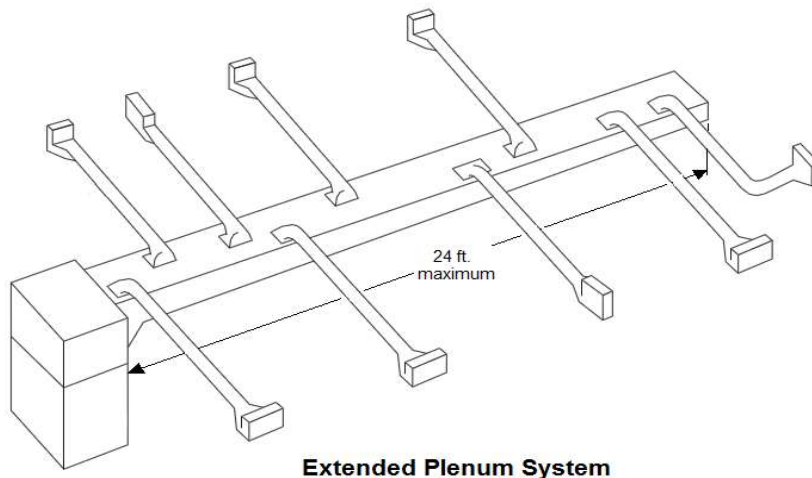

The principal design limitation of the extended plenum is the maximum length of the main supply trunk (of single size), which is usually limited to about 24 feet. When this length is exceeded, pressure tends to build up toward the end of the duct, resulting in too much air flow near the ends and insufficient air flow in branches closer to the air handler.

However, the extended plenum system can be modified to provide a double span, up to 48 feet long, when the equipment is centrally located. See the figure below.

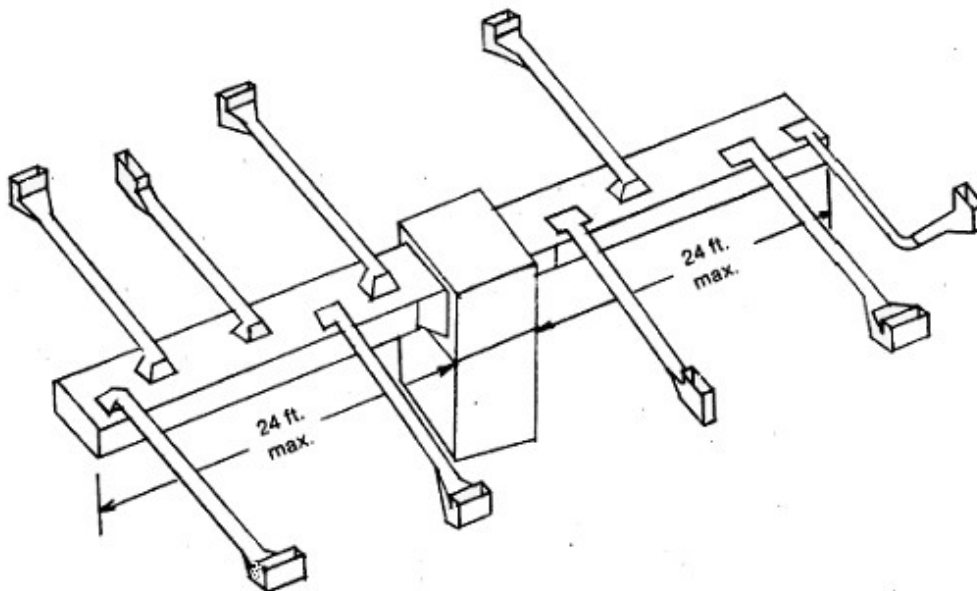

Extended Plenum System (Double Plenum, Equipment Centrally Located)

General rules:

The following general rules apply for the extended plenum system:

- Single plenums should not exceed 24 ft. in length.
- Double plenums should not exceed 48 ft. in total length.
- Keep branch run starting collars 24 in. from the end caps.
- Never locate a takeoff in the end cap.

8.2 Reducing Plenum System

The reducing plenum duct system can be used when the physical layout of the space calls for greater distances than the length constraints imposed on the extended plenum (24 ft.). The concept of the reducing plenum system is simple: when the air velocity lost to the branch runs reaches approximately 50%, the plenum size is reduced to regain the velocity in the remaining portion of the plenum. This reduction improves the air flow characteristics at the branch ducts that are closest to the air-handling unit.

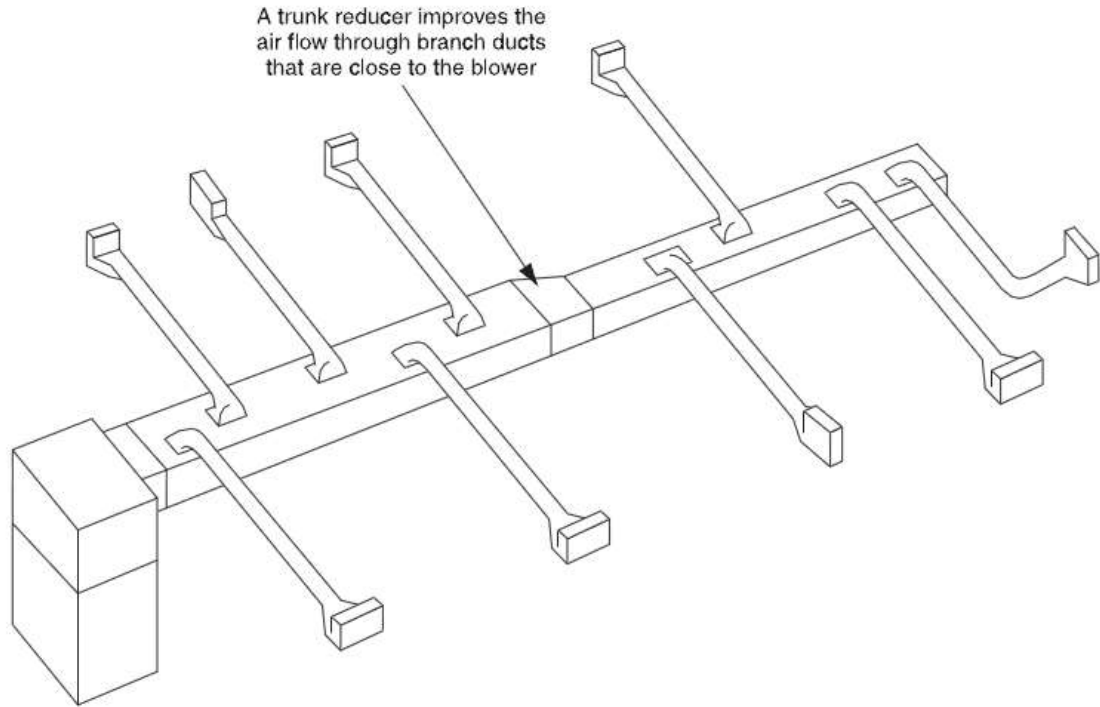

Another variation of this system is the reduced trunk system described below.

8.3 Reducing Trunk System

The reducing trunk duct system is very similar to the reducing plenum system, with the exception that the trunk run is reduced in size after each branch takeoff. The reducing trunk system reduces the cross-sectional area of the trunk periodically after every branch duct or run-out. The arrangement maintains a more uniform pressure and air velocity in the trunk, which improves air flow in branches and run-outs closer to the air handler. The system is well-balanced since each branch is specifically engineered. Effective design of reducing trunk systems requires precise determination of supply or extract air quantities for each terminal device (diffuser, register, and grille) in the room. The figure below illustrates the concept.

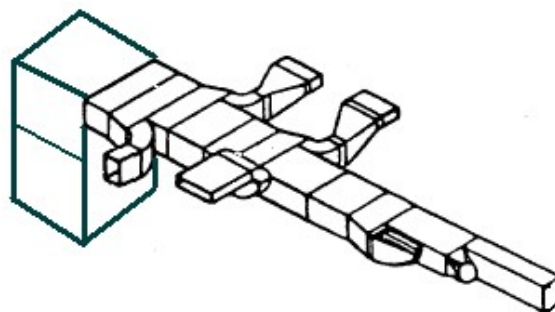

Reducing Trunk Duct System

Obviously, this type of system generally takes more sheet metal to build and requires more labor to fabricate and install.

8.4 Spider System

A spider system is a more distinct variation of the trunk and branch system. Large supply trunks (usually large-diameter flexible ducts) connect remote mixing boxes to a small, central supply plenum. Smaller branch ducts or run-outs take air from the remote mixing boxes to the individual supply outlets. The figure below illustrates this concept.

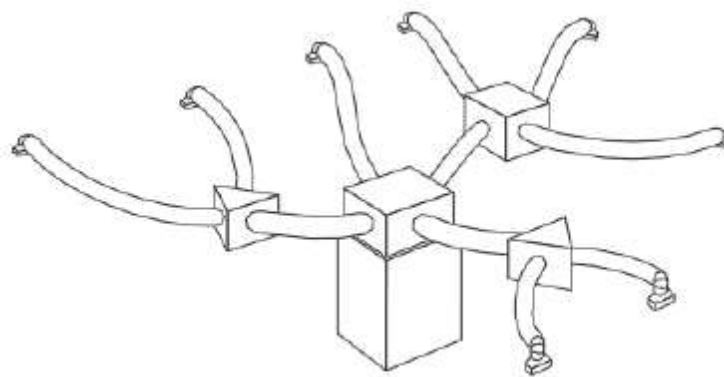

Spider Duct System

8.5 Radial System

In a radial system, there is no trunk duct, branch ducts or run-outs; rather individual supply outlets are essentially connected directly to the air handler, usually using a small supply plenum. The short, direct duct runs maximize air flow. The radial system commonly is applied in attics, crawl spaces, and in slab on grade installations (with the ducts embedded in the slab). It can be used with up-flow, down-flow, or horizontal air handlers and furnaces.

Traditionally, this system is associated with an air handler that is centrally located so that ducts are arranged in a radial pattern. However, symmetry is not mandatory, and designs using parallel run-outs can be designed so that duct runs remain in the conditioned space (e.g., installed above a dropped ceiling).

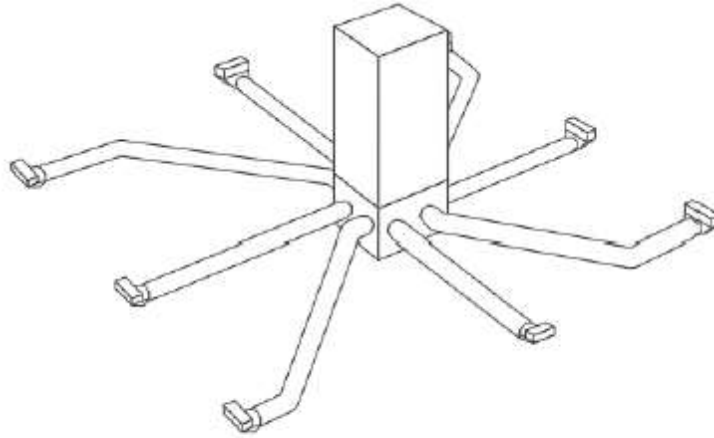

Radial Duct System

The radial system is most economical and easiest to install, but is not practical if the air handling unit cannot be centrally located.

8.6 Perimeter Loop System

A perimeter loop system uses a perimeter duct fed from a central supply plenum using several feeder ducts. This system is typically limited to facilities built on slab in cold climates.

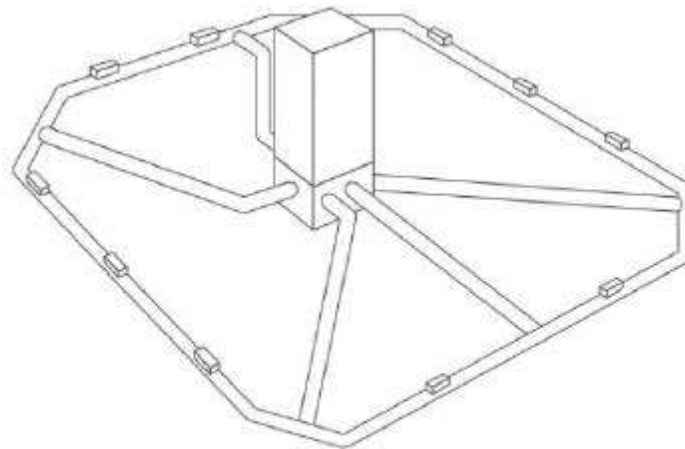

Perimetric Loop System

8.7 Rules of Duct Design (ACCA Manual D – Residential Duct Systems)

- Up to 24' of trunk length: use one size
- Over 24': reduce trunk duct every 15' to 20'
- Use tapered reducer for trunk reduction on capped trunk

- Standard trunk is 8" high
- Trunk width not to exceed trunk height by more than 4 times
- Use offset take-offs rather than straight take-offs
- Stagger the branch take-offs
- Damper each run as close to the trunk as possible
- Neither branch off any closer than 12" to the end nor off the end of a trunk
- No take-off 4' after a reduction or 1.5 times the greater dimension of the duct
- Never take-off a reduction or increase the mains any closer than the diameter of the branch duct
- On supply and return, when the trunk is wider than the plenum, a transition fitting must be used

9.0. RETURN DUCT SYSTEMS

Air conditioning systems not only supply air flow to rooms, but they pull air out of the rooms, also. If the return flow is not free to exit the space, the pressure will build up in the room and the lost air must be replaced. This causes increased quantities of outside air, which can bring additional heat, humidity and other undesirable elements with it. The supply air must therefore be balanced to maintain neutral air pressure within the space. This is done by designing ductwork with an adequate number of return ducts (or grilles). Return duct systems are generally classified as either central or distributed return.

9.1 Distributed Return

In a distributed return, each room has a return duct that provides a pathway for air to flow back to the air handler. The scheme ensures that the air flow is returned from all rooms, avoids too much positive pressurization, minimizes pressure imbalances, improves privacy, and is quiet. However, design and installation costs are generally higher than for a central return system, and higher friction losses can increase blower requirements.

9.2 Central Return

In a central return duct system, return grilles are located in central locations on the common plenum, usually close to the air handler. To ensure proper air flow from all

rooms, especially when doors are closed, transfer grilles or jumper ducts must be installed in each room.

Central return ducts should have at least one 90 degree bend between the air handler unit and the central return grille, and the air speed at the face of the return grille should be designed at 350 fpm. This keeps noise in check while allowing enough negative pressure in the return box to draw in outside air with the central-fan-integrated supply ventilation system. To size the return grille, use the equation below and divide the result by 0.65 to account for about 65% free area, which is normal for stamped return grilles.

$$A = q / v$$

where,

- A = area in square feet
- v = air speed (ft/min)
- q = volumetric air flow rate (cfm)

Central return duct systems offer the following advantages:

- They require less ductwork than a distributed system.
- They lower energy loss, since larger plenum space provides a more direct path for air flow.
- They reduce installation time and cost of materials.

9.3 Pressure Balancing

The return openings will need to be 2 to 3 times the size of the supply duct depending on system design velocities. This can take the form of transfer grille and jump ducts.

1. **Transfer Grilles:** They allow air to move from one space to another to alleviate pressure differences. For example, a transfer grille installed above a bedroom door enables air to move between the bedroom and the hallway, regardless of whether the door is open or closed. Door undercutting can help as well (for example $\frac{3}{4}$ inch undercut of a 32" door will create 24 sq. in. open area) but isn't normally sufficient on its own. A transfer grille and/or jump ducts are often required to equalize pressure and prevent over pressurization of

spaces. A “Rule of Thumb” considers 1 square inch of wall opening per cfm delivered to the room.

2. **Jump ducts:** They are short ducts that connect adjacent rooms and help balance air flow between rooms in cases where there’s one shared return grille serving the whole floor. As a general rule, no room will have less than a 6” diameter jump duct and, if more than 250 cfm needs to be transferred back to the main return area, it may be advisable to run a dedicated return duct to that area instead.

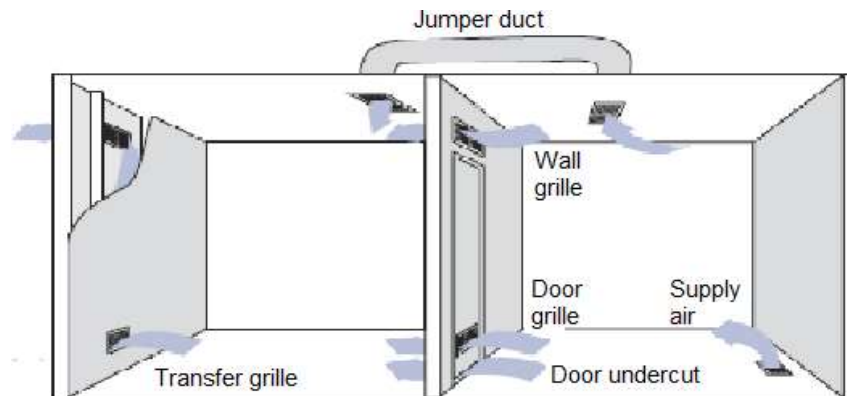

10.0. DUCT FITTINGS AND TERMINAL UNITS

10.1 Duct Fittings and Transitions

Duct losses occur across fittings and transitions. While SMACNA standards are almost always the guiding document for construction, the experience has shown that proper techniques are not always followed during fabrication and installation. Design engineers often do not allow sufficient room to install proper sized transitions or offsets. Often during installation, there is insufficient room and the fittings are squeezed into tighter spaces. Good engineering practices include:

- Unless a reduction of two inches can be made, the original duct size should be maintained.
- The slope of transition shall be 8 degrees to a maximum of 14 degrees. When the duct area is increased, the slope is not to exceed eight degrees.

- Use radius elbows rather than square elbows whenever space allows. Where a full radius elbow cannot fit, a part-radius elbow or square elbow with one or more splitters should be used.
- Turning vanes should only be used on low velocity systems where radius elbows will not fit.

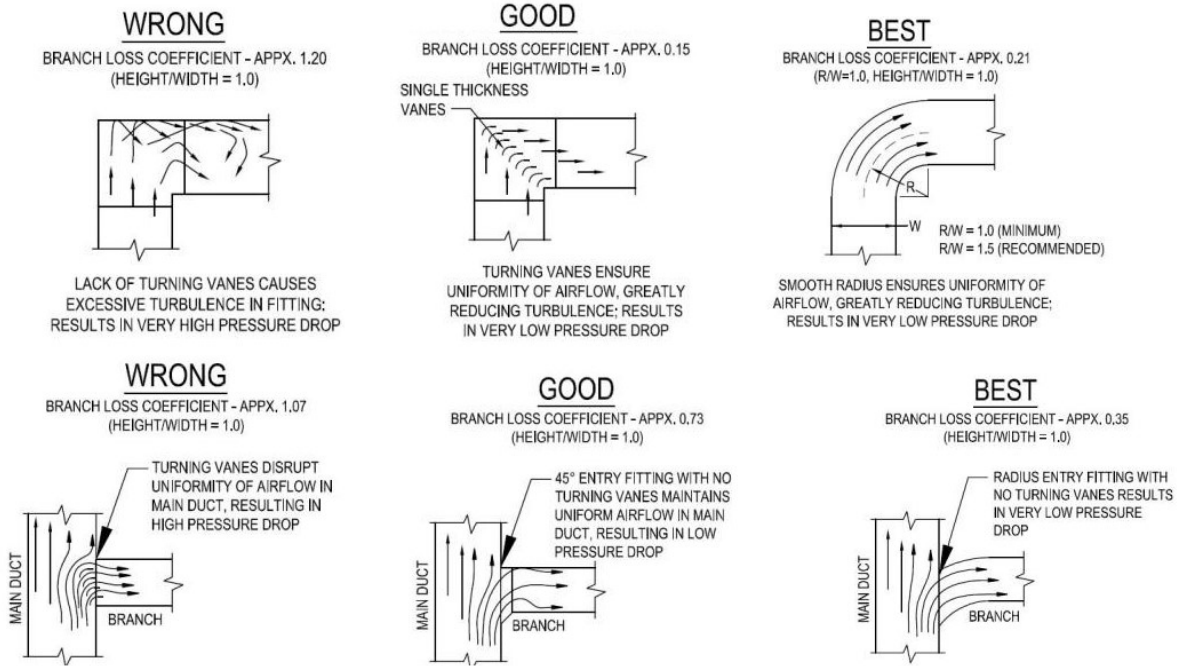

10.2 Volume Control Dampers

Dampers are used to control air flow. They may be required to fully shut off air flow or regulate flow. Two main types are in use: parallel blades where the blades rotate in one direction, or opposed blades where the adjacent blades rotate in opposite directions.

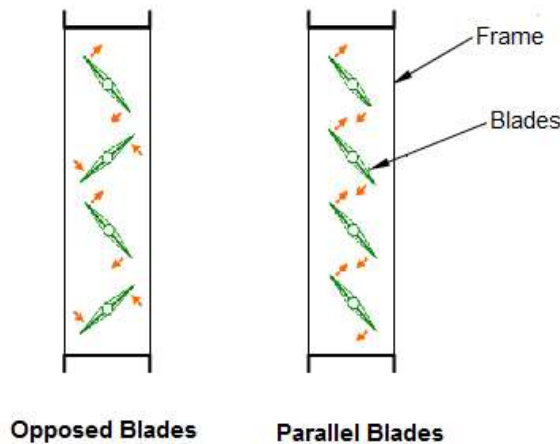

Pressure loss across the damper and leakage through a closed damper are two performance criteria affecting the selection of dampers. Parallel blade dampers are best suited for full-open or closed requirements or for fine control between 80% to 100% full flow. Opposed blade dampers are best for systems where air volume is changed over a wide range. AMCA recommends using an opposed-blade damper when volume control is needed.

Balancing/volume adjusting dampers should be installed close to the main supply, as far away as possible from the outlets. Terminal dampers such as those used in registers and diffusers should not be considered in branch balancing as they are meant to be used for fine adjustment only and would normally be in an almost fully open position to prevent unnecessary noise.

10.3 Fire and Smoke Dampers

A fire damper is a device installed in ducts and air transfer openings to interrupt the passage of flame and maintain the integrity of the fire rated separation. Fire dampers are equipped with a fusible link (rated for 165°F up to 286°F) that holds the blades open until it the link melts. Upon reaching the melting point, the blades then close and stop the flame from moving into an adjoining compartment.

Location: Fire dampers shall be installed in or near the wall or floor, at the point of duct penetration, to retain the integrity and fire rating of a wall or floor whether it is a ducted or open-plenum return application. Should the ductwork fall away, the damper needs to stay in the wall or floor to maintain the integrity of the wall or floor. One should actually think of the fire damper as part of the wall system itself.

Smoke dampers are defined as a device designed to resist the passage of smoke through the HVAC system, or from one side of a fire-rated separation to the other.

Location: They must be installed no more than 24 inches from the smoke barrier. Of course, smoke dampers that are used to isolate air handlers are not limited to this distance requirement. NFPA 90A states that smoke dampers are to be used to isolate air handling units over 15,000 cfm.

10.4 Diffusers, Grilles & Registers

Diffusers are the terminal devices that supply air in various directions through the use of their deflecting vanes. These are designed to promote the mixing of conditioned air with the air already in the space.

Grilles are defined as air devices that are typically used to return air back to the fan or to exhaust air from a space. Grilles are generally not used in supply distribution due to their inability to control the air.

Registers look like grilles but are comprised of one-way or two-way adjustable air stream deflectors and dampers to restrict the amount of air flow required to be returned, supplied or exhausted.

Steps for Selecting Air Terminals:

- a. Determine the air flow requirement and room size.
- b. Select the appropriate diffuser.
- c. Determine the velocity, throw, noise and pressure drop across the diffuser.

Let's check the characteristics of diffuser (item c) with a help of an example. Table below provides performance conditions of typical diffusers:

Air flow (cfm)	50	60	70	85	95	110	120
Velocity (fpm)	400	500	600	700	800	900	1000
Pressure drop (in.-wc)	0.056	0.090	0.131	0.175	0.225	0.290	0.355
Noise (NC)	14	20	24	28	32	35	38
Throw (ft)	5-8-13	7-9-12	8-12-19	9-13-18	10-15-21	12-17-24	13-19-31

Air velocity: It is the normal air velocity used for comfortable air distribution is **50 fpm** while the acceptable range is from 25 to 75 fpm.

Pressure drop: It is the pressure drop across the diffuser increases at higher velocities.

Noise Criteria (NC): NC increases at higher velocities. If a typical space requires a NC rating of 28-32, the corresponding maximum air flow is somewhere between 85 and 95 cfm.

Throw: Throw is defined as the horizontal distance from a diffuser at a specified velocity. For example, T50 = 15', indicates that at a distance of 15' from the diffuser, the velocity of the air will be 50 feet per minute. T100 = 10', indicates the distance at

which the air velocity is 100 feet per minute, and $T_{150} = 5'$, indicates the distance for 150 feet per minute. Often times throw is shown simply in the following format: $[T_{150} - T_{100} - T_{50}]$. For example, in the table above, air flow of 60 cfm results in a velocity of 150 fpm at 7' from the diffuser, a velocity of 100 fpm at 9' from the diffuser, and a velocity of 50 fpm at 12' from the diffuser.

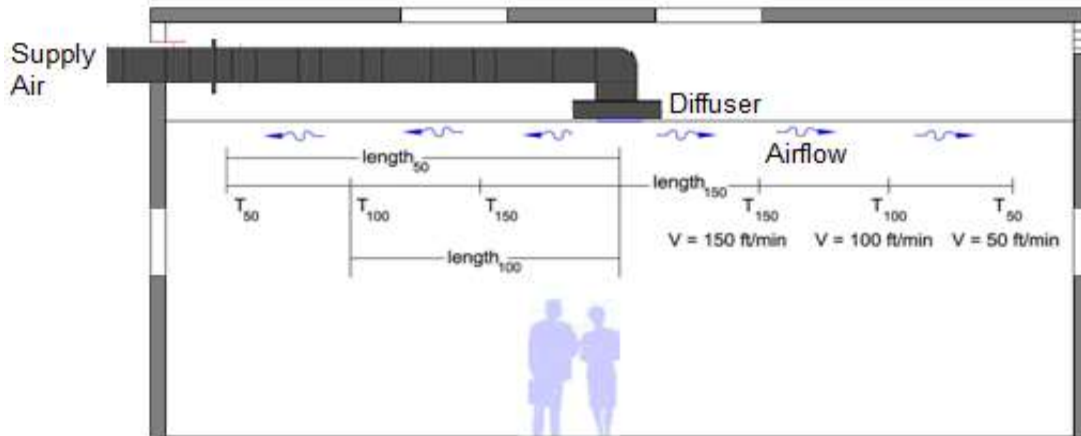

10.5 Location of Air Inlets and Outlets

A supply diffuser is responsible for most of the air movement within a room. As supply air leaves a supply register, it has a certain volume of flow rate expressed in cfm; that is the primary air. As soon as this air leaves the outlet, it begins to attract secondary air already existing in the room. This room air joins the primary air and is carried along with it. The moving air stream has now a much greater volume by the time it reaches the end of its throw. This total volume divided by the primary air volume is called the aspiration ratio. A high aspiration ratio is good, because it means that a greater quantity of air is kept in motion, with less chance of stagnation in parts of the room and with less chance of temperature stratification within the room.

The following key point should be noted:

- Locate diffusers so that the T_{50} length is nearly equivalent to the characteristic length, which is defined as the distance between the center line of the diffuser and the wall or the distance between the centerline of two diffusers.
- When cooling is the dominant space-conditioning, install ceiling diffusers or high wall outlets that discharge air parallel to the ceiling.

- c. A return air inlet that is located directly in the primary air stream of the supply outlet will short circuit the supply air back into the return without mixing with room air. Place the returns high when cooling is the dominant factor, and low when heating is the dominant factor.
- d. Special situations that require careful attention by the designer are the location of return and exhaust inlets in bars, kitchens, lavatories, dining rooms, club rooms, etc. These normally should be located near or at the ceiling level to collect the warm air "build-up," odors, smoke, and fumes.

11.0. DUCT CONSTRUCTION & REINFORCEMENT

The Sheet Metal and Air Conditioning Contractors National Association (SMACNA) defines the duct construction standards for rectangular, round and oval ductwork for positive or negative pressure classes up to 10" water column. Duct construction standards allow an estimator to specify what gauges, connections, reinforcing and tie rods are to be used for rectangular, round and oval ducts.

11.1 Duct Construction

Duct walls, transverse joints, longitudinal seams and reinforcements at or between joints make up the basic elements of duct construction. Each size in a pressure class has a minimum duct wall thickness and a minimum specification for joints and reinforcements. The details are available in SMACNA 3rd edition 2005 guides.

TRANSVERSE JOINTS

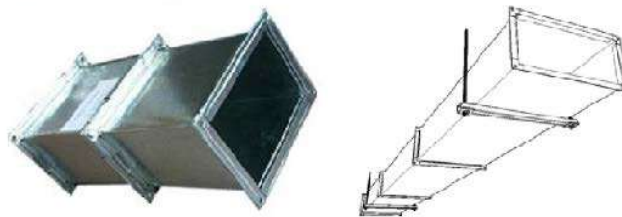

LONGITUDINAL SEAMS

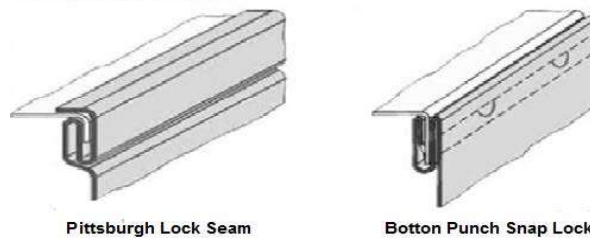

Pittsburgh Lock Seam

Bottom Punch Snap Lock

11.2 Duct Sheet Metal Thickness

The galvanized sheet metal is a common material for ductwork. The sheet metal thickness is specified in “gauge” and the greater of duct’s dimension determines the sheet thickness (gauge). The table below provides the general guidelines. Refer to SMACNA guides for more realistic thicknesses based on operating pressures.

Rectangular Duct			Round Duct		
Greater Dimension	G. Steel (gauge)	Al (gauge)	Diameter	G. Steel (gauge)	Al (gauge)
Up to 30 inch	24	22	Up to 8 inch	24	22
31 – 60 inches	22	20	9 – 24 inches	22	20
61 – 90 inches	20	18	25 – 48 inches	20	18
> 91 inches	18	16	49 – 72 inches	18	16

Note that the lower the gauge, the thicker is the sheet metal.

The galvanized sheet metal recommended for ductwork should have a zinc coating at least 1.25 ounces (35.4 g) per sq.-ft. on both sides of the sheet and should be of lock-forming quality. The weight of galvanized steel is as follows:

24 gauge = 1.156 lbs./sq.-ft.

22 gauge = 1.406 lbs./sq.-ft.

20 gauge = 1.656 lbs./sq.-ft.

18 gauge = 2.156 lbs./sq.-ft.

Cost of galvanized steel = \$16 per lb.

11.3 Aspect Ratio

The aspect ratio is an important factor to classify cost and air flow effectiveness of a rectangular duct. The aspect ratio is the relationship between the width (w) and height (h) of a duct, expressed as a ratio of w/h.

Increasing the aspect ratio, increases both the installed cost and the operating cost of the system. A rectangular duct with an aspect ratio closer to 1 will use the lowest

sheet metal. Other benefits include low friction drop, low weight of metal, and lower insulation and installation costs.

Example:

A duct with a cross-sectional area of 4 sq.-ft. and 100-ft. length can be fabricated as 2' x 2' or 1' x 4' dimensions.

In the 1st case, 2' x 2', the perimeter = 8 ft, total sheet metal required is 8 x 100 = 800 sq.-ft.

In the 2nd case, 1' x 4', the perimeter = 10 ft, total sheet metal required is 10 x 100 = 1000 sq.-ft.

As the aspect ratio increases from 1:1 to 1:4, the surface area and insulation requirements increase 40% percent.

11.4 Standard Duct Sizes

A standard air conditioner moves 400 cfm of air per ton. One ton of refrigeration equates to the heat extraction rate of 12,000 Btu's per hour. British thermal unit (Btu) is the measurement of heat. It takes one Btu to raise the temperature of water to one degree Fahrenheit.

A 6-inch duct and an 8-inch duct carry about 100 cfm and 200 cfm of cool air, respectively. Here are some sizes for the supply duct that can be used.

Air Flow	Duct Diameter	Duct Size (1)	Duct Size (2)	Tonnage
100 cfm	6" round	5" x 6"	4" x 8"	
200 cfm	8" round	6" x 8"	4" x 12"	½ ton
300 cfm	9" round	10" x 7"	5" x 14"	¾ ton
400 cfm	10" round	8" x 10"	6" x 14"	1 ton
600 cfm	12" round	10" x 12"	8" x 14"	1½ tons
800 cfm	13" round	10" x 14"	8" x 18"	2 tons
1000 cfm	14" round	10" x 16"	12" x 14"	2½ tons
1200 cfm	16" round	10" x 20"	12" x 16"	3 tons
1400 cfm	16" round	12" x 18"	10" x 20"	3½ tons

1600 cfm	18" round	14" x 16"	12" x 20"	4 tons
2000 cfm	18" round	12" x 25"	16" x 17"	5 tons

Make sure that the return ducts are larger than, or at least the same size as, the supply ducts.

11.5 Duct Fabrication and Lengths

Straight, standard length ducts cost less since duct machines, such as coil lines for rectangular ducts, automatically produce duct sections usually 5 feet long. Any rectangular duct that is not a standard length is technically a fitting since it cannot be made by the coil line. While a spiral round duct can virtually be of any length, it is commonly cut to 20-foot sections to fit in a standard truck. Oval duct standard lengths vary depending on the fabricator but manufactured ducts are typically 12 feet long. It is not uncommon for an inexperienced designer to include too many duct size reductions with the false impression that reducing duct sizes will reduce costs.

Examples of Poor and Better Duct Design

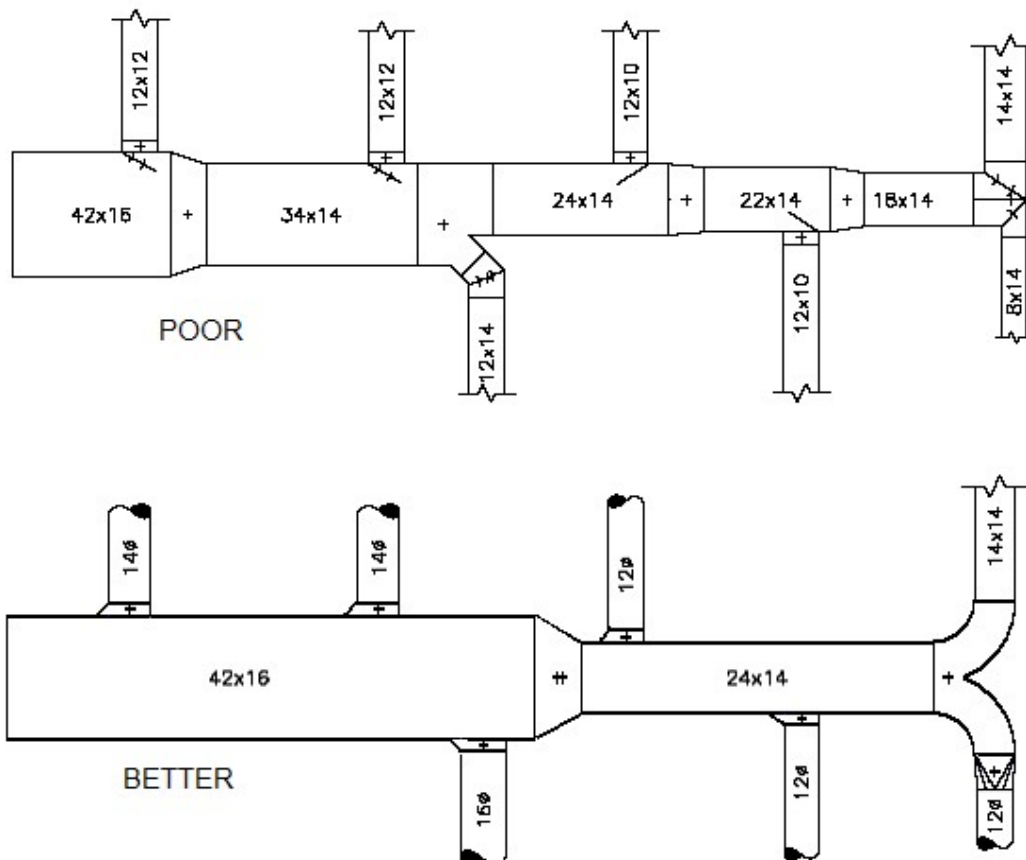

11.6 Duct Hanger Spacing

Cross-Sectional Perimeter of Duct	Maximum Spacing between Hangers
Horizontal ducts less than 4 ft.	8 ft.
Horizontal ducts 4 ft. to 10 ft.	6 ft.
Horizontal ducts greater than 10ft.	4 ft.

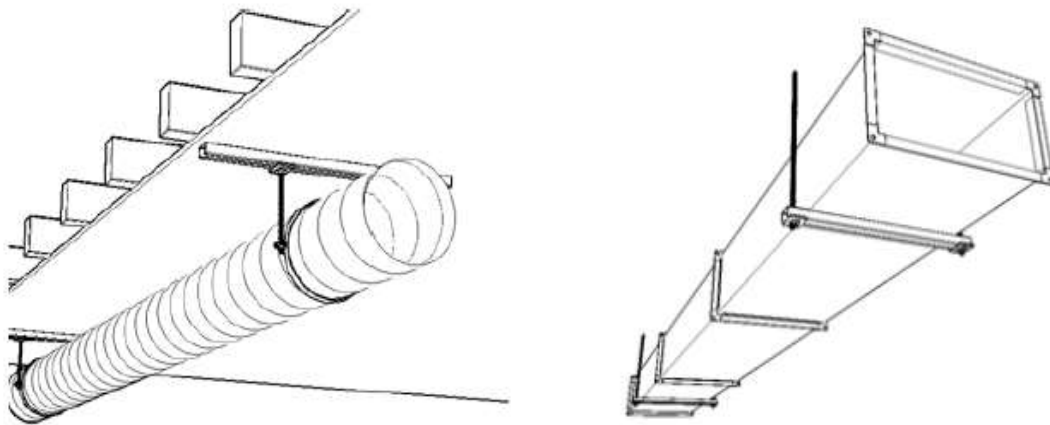

Duct Hanger

12.0. GOOD ENGINEERING PRACTICES

12.1 Energy Conservation

Typical duct systems lose 25 to 40 percent of the heating or cooling energy. Buildings with ducts in a protected area (such as a basement) may lose somewhat less than this, while some other types of systems (such as attic ducts in hot, humid climates) often lose more. Duct systems lose energy in two ways:

1. The first way is via heat transfer through the duct walls. Ducts in a conditioned space are the most energy-efficient ducts. Ducts running through unconditioned spaces, like an attic or crawlspace, should be insulated. Heat gains and losses are minimized and go directly to the conditioned space.

2. The second is via air leakages through accidental holes or through open spaces between poorly connected sections of ductwork. Leaky supply ducts cause depressurization of the structure, and outside air is forced in through cracks in the envelope. Leaky return ducts cause pressurization, which forces conditioned inside air out of the structure. Sealing both supply and return ducts minimizes energy loss by infiltration.

12.2 Good Engineering Practices for Designing Ductwork

Air distribution within the space is critical to maintaining space conditions and minimizing noise concerns. Here are some key guidelines for designing ductwork that should be followed to get the most out of your system:

1. **Configuration:** Ducts should be designed so that the length of each run (each section of ductwork) is short enough to provide proper control of air flow and stability of construction. Radial or trunk-&-branch configurations have shorter runs and generally work best. Wherever possible, ducts should be located within the conditioned space. Long meandering sections of ductwork can lead to trouble, such as ducts collapsing over time or becoming twisted and blocked.
2. **Go straight:** this is the most important rule of all. From an energy perspective, air wants to go straight and will lose energy if you make it bend. From a cost perspective, straight duct costs less than fittings. Fittings are expensive because they must be hand assembled even if the pieces are automatically cut by plasma cutters. So, when laying out a system, try to reduce the number of bends and turns to an absolute minimum.
3. **Make sure ducts are the correct size:** Ductwork that's too small won't be able to carry enough air to heat or cool your building. Ducts that are too large can lose both air and energy, cutting system efficiency, and wasting money. Use trusted industry standards and procedures, such as those published by ASHRAE, to size your ducts.
4. **Make sure there are enough return ducts:** Supply ducts carry conditioned air to your building, but the system also requires enough return ducts to bring expended air back to the HVAC unit to be conditioned again. Each room that receives heating or cooling should have at least one return duct. As a rule of thumb, use 2 cfm for each sq.-inch of return air opening;

for example, 20" x 20" grille equals 400 sq.-in. gross area of grille, which means 800 cfm of recommended air flow.

5. **Be careful where you install ducts:** Ducts placed in conditioned spaces are more efficient than those placed in unconditioned spaces. If located within conditioned space, conductive and radiative losses, leakage losses, and equipment cabinet losses are reduced or regained into the building space. If it is not feasible to locate ductwork within conditioned spaces, the ducts should be properly sealed and insulated. The trunk ducts are usually located above corridors in the cavity above the ceiling to minimize noise transmission to the conditioned zones and allow easy access without disturbing the building occupants.
6. **Thermal Zoning:** Zoning is a practice of dividing a building into distinct thermal zones, which have similar heating and cooling requirements. In practice the corner rooms and the perimeter spaces of the building have variations in load as compared to the interior core areas. The buildings are usually divided into two major zones.
 - **Exterior Zone:** This is the area inward from the outside wall (usually 12 to 18 feet, if rooms do not line the outside wall). The exterior zone is directly affected by outdoor conditions during summer and winter and has variable thermal loads.
 - **Interior Zone:** This is the area contained by the external zone. The interior zone is only slightly affected by outdoor conditions and usually has a uniform and steady cooling load throughout.

Few areas, for example, conference and meeting rooms are influenced by variable occupancy loads. The concept of thermal zone is important to size HVAC equipment and plan the way ducting is routed. If zones have special temperature and/or humidity requirements, they should be served by independent air distribution systems separate from variable zones. The idea is to permit independent control of temperature and humidity in similar zones. Where it is not possible, consider use of VAV systems and/or supplementary controls.

7. **Seal and insulate:** Make sure all ductwork sections fit together tightly. Connections can be mechanically sealed with sheet metal screws or other fasteners to improve connection strength. Seal connections with mastic or metal tape. Cover the ductwork with insulation, such as rigid fiber board or standard blanket-type insulation.

8. **Rules of Thumb:**

- **10% Rule:** For supply ducts longer than 10 feet, the air is reduced in that run by 10% for every 5 feet over 10 feet. For example, a 30 foot run yields a reduction of 40% ($30-10=20$, $20\div 5=4$, $4\times 10=40\%$). Minimize length and restrictions. Keep the supply duct length as close to 10 feet as possible but never less than 6 feet. Use the fewest number of bends as possible.
- **24-inch Rule:** Use at least 24 inches of straight plenum before any fitting, such as an elbow, tee, or takeoff. Electric duct heaters require 48 inches. Avoid elbows directly off units. The maximum total plenum length should be restricted to 150 ft. For the plenum, maximize length and minimize restrictions.
- **60/40 Rule:** When using a tee, split the flow as close to 50/50 as possible, no more than 60/40. Always use a turning vane.
- **70/30 Rule:** Turn the tee 90° to make a side branch with no more than 30 percent of the air. Do not use a turning vane.
- **Takeoffs:** Maintain distance between takeoffs as evenly as possible. Space the takeoffs at least 6 inches apart and 12 inches from the end cap.
- **Fittings:** Use long and radiused duct fittings instead of short or mitered fittings wherever possible.

13.0. DUCTWORK INSULATION AND SEALING

13.1 Ductwork Insulation

Insulation is applied to ductwork to minimize the rate of thermal loss through the skinny sheet metal. Ducts may also sweat when their surface temperature is below

the dew point of the surrounding air. This can lead to water damage and microbial growth within the building.

A 15°F temperature difference from the inside of the duct to the outside of the duct is considered the maximum difference allowed before insulation is necessary. One-inch-thick fiberglass blanket (R value of 16) is almost always sufficient for thermal protection. Return air ducts only need to be insulated if they pass through environments that adversely affect the return air temperature.

The insulation is joined by lapping it, stapling it, and taping it. A protective cover with a vapor barrier such as an aluminum foil should be included in the insulation specifications.

13.2 Ductwork Air Leakage

Duct leakage refers to the leakage of air from the air distribution system ductwork. The leakage can occur at joints, seams and penetrations. This leakage causes two problems: 1) some areas at the end of the run may be short of air flow, and 2) the fan energy increases as the cube of the air leakage increases. For example, if a system has 10% leakage and the fan design was originally 20 Horsepower (HP), the new motor required to overcome the 10% loss will be $20 \text{ HP} \times (1.1)^3 = 26.6 \text{ HP}$. In this case, the owner pays the equivalent of 6.6 HP in additional fan energy for the life of the building.

The air duct leakage can be represented as a function of the duct surface area, leakage class, and static pressure. Leakage class is determined by the construction methods employed in duct fabrication in accordance with the ANSI/SMACNA HVAC duct construction standards.

13.3 Duct Leakage Tests

Ductwork that is designed to operate at static pressures in excess of 3 inches Water Column and is located outdoors shall be leak-tested according to the SMACNA HVAC Air Duct Leakage Test Manual. Positive pressure leakage testing is acceptable for negative pressure ductwork. The maximum permitted duct leakage shall be:

$$L_{max} = (CL) * (P)^{0.65}$$

where,

- L_{max} = maximum permitted leakage in cfm/100 square feet of duct surface area;
- CL = duct leakage class, cfm/100 square feet of duct surface area at 1 inch Water Column. SMACNA has defined duct leakage rates as Leakage Class 24, 12 or 6. These numbers simply mean that at 1 inch of test pressure, ducts can be expected to leak 24, 12 or 6 cfm per a square foot of duct surface.
- P = test pressure, which is equal to the design duct pressure class rating, in inch Water Column, based on ASHRAE 90.1:6.4.4.2.2

Ductwork that is designed to operate at static pressures less than 3 in.-WC and located outdoors or within unconditioned space, shall be leak-tested according to the testing procedures contained in SMACNA HVAC Air Duct Leakage Test Manual.

13.4 Duct Sealing

Duct sealing is a process of applying approved materials or sealants on the duct joints prone to air leakages. Locations where sealing is typically performed include the supply and return plenums, starting collars where ducts are connected to the plenums, fittings in the duct runs, splices within the duct run, and terminations where the ducts connect to the supply registers.

Approved Sealants:

Sealants should be UL 181 listed, water based, non-toxic, and water resistant with high solids content. Approved sealants are flexible gaskets, fibre-reinforced mastic, or mastic used with mesh tape. Duct systems sealed with mastics generally exhibit lower leakage. Mastic sealant utilized should be water-based, non-toxic, consist of at least 50% solids, and be UL 181 approved.

Materials not recommended:

Foil tapes, cloth-backed duct tapes, or pressure sensitive tapes are not suitable. Oil base caulking and glazing compounds should not be used.

Both ASHRAE and SMACNA standards specify the duct sealing requirements in terms of seal classes A, B and C.

ASHRAE Standard 90.1-2004 Ductwork Seal Classes

Seal Level	Sealing Requirements
Seal Class A	All transverse joints and longitudinal seams, and duct wall penetrations. Pressure-sensitive tape shall not be used as the primary sealant.
Seal Class B	All transverse joints and longitudinal seams. Pressure-sensitive tape shall not be used as the primary sealant.
Seal Class C	All transverse joints only

SMACNA-HVAC Ductwork Seal Classes

- **Seal Class A:** 2 to 5 percent total system leakage (all transverse joints, longitudinal seams, and duct penetrations).
- **Seal Class B:** 3 to 10 percent total system leakage (all transverse joints and longitudinal seams).
- **Seal Class C:** 5 to 20 percent total system leakage (all transverse joints).
- **Unsealed:** 10 to 40 percent total system leakage.

14.0. DUCT ATTENUATION AND NOISE CONSIDERATIONS

The HVAC industry has established noise criteria (NC) values for evaluating the acceptability of sound levels. NC values for different types of buildings range from 30 to 40 decibels. A decibel is a unit of comparative sound measurement (a whispered conversation at a distance of 6 ft. from the ear, for example, has a sound pressure level of 30 decibels).

14.1 HVAC Noise Points

The figure below shows the noise points from a typical HVAC system.

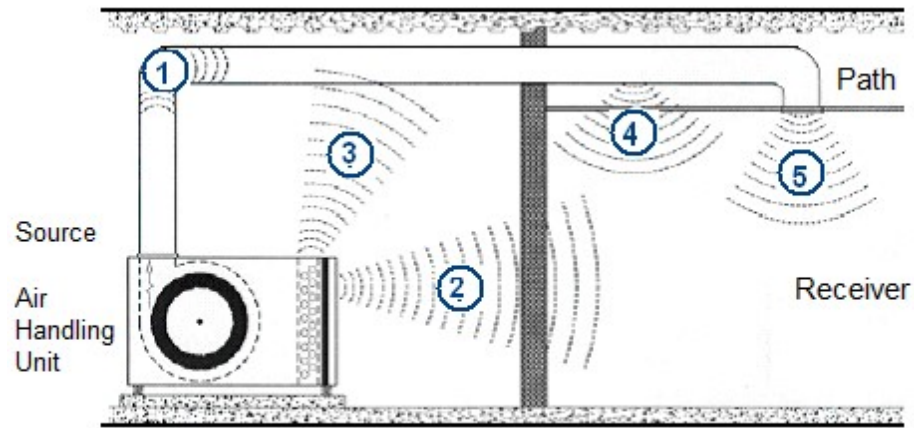

TYPICAL MECHANICAL SYSTEM NOISE COMPONENTS

The major source of noise in air conditioning systems is due to air velocity as well as the noise from fan. The 5 distinct paths of noise are:

1. **Duct borne noise:** It is caused by the flow of air and directly dependent on the velocity of air.
2. **Radiated equipment noise:** It is caused by vibration of equipment and inherent sound pressure of the equipment.
3. **Break-in noise:** It is radiated equipment noise that enters the ductwork and propagates down the duct system.
4. **Break-out noise:** It transmits through the wall of the duct.
5. **Terminal end noise:** It is caused by the air flows at the terminal devices such as diffuser or register.

14.2 Acoustical Analysis of a Ductwork System

Noise due to air is roughly proportional to the 5th power of the fan speed. If the speed of a fan is reduced by 10%, the db will be reduced by 2 dB. If the fan speed is reduced by 20% and 30%, it will yield a noise reduction of 5 dB and 8 dB, respectively.

Based on the aforementioned analysis, the following recommendations are made:

Duct borne Noise:

1. Keep air velocity low and liberally size the ducts. The air velocity in the main duct should be limited to 1,500 fpm and the velocity through the branch ducts should be less than 800 fpm.
2. Select the fan at maximum efficiency point.
3. All VAV installations must have variable frequency drives.
4. The ductwork must be routed, fabricated and supported in accordance with SMACNA guidelines.

Radiated Equipment Noise:

1. Use vibration isolators between the equipment and the building structure. Common materials used as vibration isolators are rubber, cork, various types of steel springs, and glass fiber pads.
2. Use flexible fabric connections between the fan and duct.
3. Avoid locating the HVAC unit in a space immediately adjacent to the occupied space.
4. Acoustically insulate the mechanical room walls and ceilings with fiber insulation mounted on wooden battens. The insulation shall be clad with perforated Aluminum sheet of 36 gauge.

Duct Break-In and Break-Out Noise

1. Ensure low air flow velocity. The air velocity in the main duct and branch duct should be limited to 1,500 fpm and 800 fpm, respectively.
2. Ensure ducts do not vibrate. Ducts can be made stiffer by adding external bracing and/or adding damping (spray on or self-adhesive compounds).
3. Avoid abrupt changes in duct cross-sections; most straight ductwork naturally attenuates noise and provides smooth transitional duct branches, take offs, and bends.
4. Fitting (such as elbows and transitions) should not be placed closer than 3 to 6 duct diameters downstream from a fan and duct transitions, particularly at the unit inlet and discharge openings - 15° maximum.
5. Insulate the duct with Rockwool or Glasswool to damp duct breakout noise.

6. Use internal duct lining for at least 10 to 15 feet from fan discharge. A one-inch-thick fiber glass duct insulation has an NRC of 0.7; this means it effectively absorbs 70 percent of the sound at the most common frequencies. A two-inch-thick duct liner has an NRC of 0.90, absorbing 90 percent of the sound. Caution: A two-inch lining will reduce the cross-sectional area of the duct causing an increase in velocity. This needs to be evaluated.
7. Add acoustic silencers on the fan discharge. Caution: Check the static pressure of the fan to overcome the resistance. Check space.
8. Use flexible ducts only at the terminal ends of diffusers. The flexible ducts should be completely stretched and restricted to a 6-foot length.

Terminal Noise:

1. Install at least 3 diameters straight flex at the diffuser inlet or use a minimum of 6 feet of acoustical flex between the low pressure duct and the diffuser.
2. Select diffusers, grilles and registers for “noise criteria” rating of NC-30 or lower for the designed air flow rate.

Refer to the HVAC Applications chapter, "Sound and Vibration Control" of the ASHRAE Handbook, Chapter 43, and 2003 edition for further reading.

Regenerated Noise: HVAC Designer Enemy #1

Medium and high velocity air flow impinging on any obstruction will cause disturbance of the air flow. The resultant turbulence produces regenerated noise.

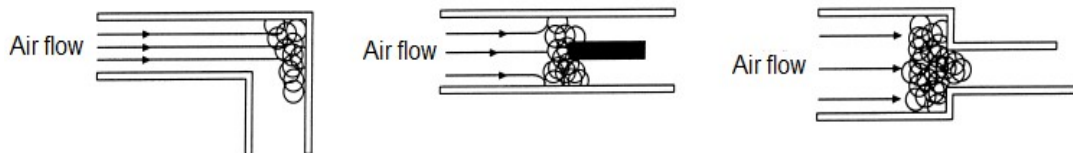

HVAC duct design components such as elbows, turning vanes, dampers, transitions, offsets, take-offs, tees, etc. are examples of such obstructions. The turbulence in most air flow systems is characterized by sharp changes in the air flow path, sharp bends, abrupt cross-sectional area changes, etc. in contrast to aerodynamic fan noise which manifests itself in a more tonal frequency spectrum at the fan blade passage frequency. Turbulence and regenerated noise are generally characterized by a broad band frequency spectrum. Turbulence increases the noise levels and system

operating costs. Regenerated noise can be minimized by ensuring smooth air flow conditions. SMACNA duct design and construction guidelines should be incorporated in all job specifications and drawings. The SMACNA guidelines also outline optimal duct silencer locations and guidelines for centrifugal fan installations (distances for placement of duct fittings).

15.0. DUCTWORK TESTING & SYSTEM PERFORMANCE

Air testing and balancing is a process that measures and adjusts the supply air distribution of a given HVAC system. The purpose of testing and balancing an HVAC system is to supply each conditioned zone with the precise amount of supply air required to offset a given heat gain (or loss). This process is typically performed after an HVAC system has been installed. The amount of air flow into each zone is determined from the mechanical design plans. However, air testing and balancing is also performed in response to certain cases of occupant thermal discomfort. If occupant thermal discomfort exists in a building with a properly sized and balanced HVAC system, fine tuning adjustments to supply registers may be necessary to satisfy all occupants. The following testing requirements are recommended:

1. Room-by-room air flows are correct;
2. Total supply is as designed;
3. Total return + exhaust = total supply;
4. Ducts, plenum, and air handler are tight; and
5. Static pressure is correct.

15.1 Balancing the System

Balancing a system involves the following steps:

1. Inspect the complete system; locate all ducts, openings, and dampers.
2. Open all dampers in the ducts and at the grilles.
3. Check the velocities at each outlet.
4. Measure the "free" grille area.
5. Calculate the air flow volume at each outlet.

6. Total the cubic feet/minute.
7. Determine the floor areas of each room. Add to determine total area.
8. Determine the cfm for each room. The area of the room divided by the total floor area multiplied by the total cfm equals cfm for the room.
9. Adjust duct dampers and grille dampers to obtain these values.
10. Recheck all outlet grilles. In some cases, it may be necessary to overcome excess duct resistance by installing an air duct booster. These are fans used to increase air flow when a duct is too small, too long, or has too many elbows.

15.2 Testing Methods and Equipment

Duct testing is the process of using calibrated mechanical equipment to measure the amount of air flow that is lost through the duct system when it is at normal operating pressure. While some joints or seams may have only small leaks, other sections may be completely disconnected. Duct testing can indicate the relative leakiness of the ducts and help determine whether the duct system should be sealed, repaired, or renovated.

There are two main methods of testing:

1. The *pressurization subtraction method* utilizes a pressurization unit (i.e. a high powered fan set up in a doorway and connected to pressure gauges) to pressurize first the entire space that is heated and/or cooled and then the same space with the duct system blocked off. This method is less accurate than the duct testing method.
2. The *duct testing method* uses a calibrated fan that gently pressurizes the ducts and measures the air flow through the ducts to indicate total leakage. The duct tester consists of a portable fan, with calibrated digital pressure gauges, that is connected at the blower compartment of the air handler, or attached to the main return grill. The entire duct registers and grills are temporarily sealed, and the duct tester fan is turned on to pressurize the system. The fan pressure is read from the gauges and converted to an equivalent duct leakage rate in cubic feet per minute (cfm). If the amount of air loss falls outside acceptable limits, sealing will be required to correct the

condition. This method of testing is preferred because it measures low air flow accurately, and simulates what takes place under normal operating conditions.

15.3 Air Flow Measurement Instruments

Anemometer: The anemometer is a device used to measure the velocity of air travelling through a duct or grille. Readings are measured in feet per minute (fpm).

Air flow is measured in cfm, therefore:

$$\text{Air Flow (cfm)} = \text{Velocity (fpm)} \times \text{Area (ft}^2\text{)}$$

For example, if the mean velocity in a rectangular duct 12" x 24" is 1,000 fpm, the volume flow rate is $12 \times 24 \times 1,000/144 = 2,000$ cfm.

There are three (3) type of anemometer:

- a. **Hotwire Anemometer:** This has a probe consisting of a very fine short length of wire (or small thermistor bead) attached to the end of a supporting tube. The wire is heated electrically, and measurements are made of the heat dissipated by the wire. The rate of heat dissipation is directly related to the velocity of the air passing the wire.
- b. **Rotating Vane Anemometer:** This consists of a disc of angled vanes attached to a rotating spindle and is usually mounted within a protective ring and supporting bracket. The speed at which the vane assembly rotates is a measure of the air velocity acting upon it. This speed may be sensed either electronically or by a counter mechanism.
- c. **Ultrasonic Anemometer:** This takes clean air and gas flow velocity measurements with a "mini sensor". Using three energized "posts", sound waves are transmitted sequentially 3,849 times every second. The time taken for sound to travel from one post to another and for a wave to return over the same precise distance is measured. By using the speed of sound, at 340.3 m/sec in standard air as a "carrier", the true velocity can be calculated with 100% certainty and repeatability. Any changes in ambient temperature, barometric pressure, RH and gas density conditions are rendered irrelevant for use in mixed air/inert gas density situations, without any need for corrections, re-calibration or complex calculations.

Manometer: The manometer is a device used to measure relatively low pressures or more commonly, pressure devices.

Manometers are made in two (2) different styles. Both are used to measure the pressure difference across an object, e.g. filter, coil and fan:

1. The U-Tube Manometer. In order to read the amount of pressure applied, read the value corresponding to the fluid level on one side of the tube and double it.
2. Inclined Manometer. In order to read the amount of pressure applied, read the value according to the fluid level in the tube.

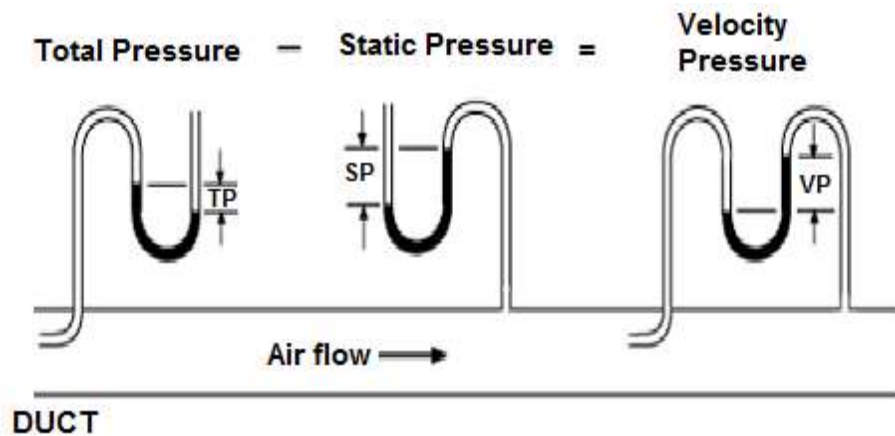

The Pitot-Tube: The pitot-tube is a device that is usually used together with an inclined manometer to measure the static pressure, total pressure and velocity pressure within a ducted system. The pitot tube assembly includes a static pressure probe and a total pressure probe. A total pressure probe, aligned into the air flow, senses the duct velocity pressure and the static pressure, which equals the total pressure. A static pressure probe aligned at a right angle to the air flow senses only the static pressure. The difference between the total pressure reading and the static pressure reading is the velocity pressure.

15.4 Determining Air Flow at Grilles

The rotating vane anemometer is often used for measuring the velocity at inlet grilles and extract openings. If the grille has directional louvers, these should be set at right angles before taking readings.

Measurement of air velocity should be made between the blades at a number of positions. The effective free outlet area of the grille can be found from the relevant manufacturer's data or estimated from the unobstructed flow area of the grille.

To determine the volume flow, the measurement instrument should be evenly traversed across the entire grille face to determine an arithmetic mean value of the air velocity. The volume flow is then:

$$Q = A_{\text{eff}} \times V_{\text{mean}} \times f$$

Where,

- Q = volume flow (cfm)
- A_{eff} = effective free outlet area of the grille (ft²)
- V_{mean} = mean velocity (fpm)
- f = correction factor for obstruction by the measuring instrument (for rotating vane anemometer, $f = 1.3$ to 1.9).

15.5 Determining Air Flow in Ducts

The pitot tube with the manometer is generally used for measuring the velocity in ducts. If you connect the total pressure probe to the HIGH port on a differential pressure sensor and the static pressure probe to the LOW port on the differential pressure sensor, then the sensor's output will be the velocity pressure.

The readings from the manometer are velocity pressure (VP) in inches of water column, and not in velocity (fpm). Therefore, it is necessary to convert velocity pressure to velocity, in feet per minute (fpm), using the following equation:

$$\text{Velocity (fpm)} = 4005 \times (\text{VP})^{1/2}$$

where,

- V = Flow Velocity in feet per minute, (fpm)
- VP = The Velocity Pressure measured by the pressure sensor, (in-wc)

After obtaining the flow velocity from the equation above, the value is now multiplied by the duct cross-sectional area to determine the air flow in cfm.

There are two different equations for determining the duct cross-sectional area, one for round ducts and one for square or rectangular ducts.

The equation for a round duct is:

$$A = \pi \times r^2$$

where,

- A = Duct cross-sectional area (sq-ft)
- $\pi = 3.14159$
- r = Duct radius in feet

The equation for square or rectangular ducts is:

$$A = w * h$$

where,

- A = Duct cross-sectional area, (sq-ft)
- h = Duct height in feet, (ft)
- w = Duct width in feet, (ft)

Example:

A pitot tube measures a velocity pressure of .75" W.C. through an 18" diameter duct. Determine the air flow through the duct.

Calculate air flow velocity:

$$\text{Velocity (V)} = 4005 \times (0.75)^{\frac{1}{2}}$$

$$V = 4005 \times 0.866 = 3,468 \text{ fpm}$$

Calculate cross-sectional area of an 18" diameter round duct:

$$\text{Diameter} = 18" = 1.5 \text{ ft.}$$

$$\text{Radius} = 1.5/2 = 0.752 \text{ ft.}$$

$$A = \pi \times r^2$$

$$A = 3.14158 \times 0.752 \times 0.752 = 1.77 \text{ ft}^2$$

Determining air flow in cfm:

$$\text{Air Flow (Q)} = \text{Flow Velocity in fpm (V)} \times \text{Duct Cross-Sectional Area (A)}$$

$$Q = 3,468 \text{ fpm} \times 1.77 \text{ ft}^2 = 6,138 \text{ cfm}$$

15.6 Provisions during Design for Testing, Adjusting and Balancing

It is important for system air to get to the occupied space with minimal losses caused from leakage and resistance, with proper mixing of air, and without temperature changes from heat gains or losses. Also important are the noise, draft, and efficiency with which air is delivered. The means to meet these requirements are the proper design of ductwork and outlets.

The designer should give special attention to the balancing and adjusting process during the design. It is necessary that the balancing capability be designed into the system initially. Below are some considerations to make when designing duct systems.

1. Sufficient lengths of straight duct must be provided in an accessible area to allow the TAB personnel to perform their function properly. This also applies in TAB work of the critical branches of the distribution system.
2. Mixing boxes should be located so the discharge ductwork will minimize air turbulence and stratification.
3. Ductwork to and from air conditioning equipment should be designed carefully so stratified air may be mixed properly before entering branch ducts or equipment.
4. Adequate size access doors should be installed within a normal working distance of all volume dampers, fire dampers, pressure reducing valves, reheat coils, mixing boxes, blenders, constant volume regulators, etc. that require adjustments within the ductwork.
5. Manually operated, opposed blade or single blade, quadrant-type volume dampers should be installed in each branch duct take-off after leaving the main duct to control the amount of air entering or leaving the branch.
6. Do not use extractors at branch or main duct take-offs because they can cause turbulence in the main trunk duct thereby increasing the system total pressure, and affecting the performance of other branch outlets downstream. Extractors are principally used to divert air to branch ducts.

16.0. DUCT CLEANING

There is also the question of when duct cleaning should be done, and how the job could be validated. Duct cleaning may be warranted in any of the following situations:

- There is substantial evidence of visible mold growth inside the hard surface of ducts or on other components of the heating and cooling system. Get laboratory analysis carried out for the sample before taking the decision.
- If you have insulated air ducts and the insulation gets wet or moldy, it cannot be effectively cleaned and should be removed and replaced.
- Ducts are infested with vermin, e.g. (rodents or insects).
- Ducts are clogged with excessive amounts of dust or debris, whereby particles are actually released into the home from the supply registers.

According to the Environmental Protection Agency (EPA), duct cleaning has never been shown to actually prevent health problems. Moreover, studies do not conclusively demonstrate that particle levels in homes increase because of dirty air ducts. This is because much of the dirt in the air ducts adheres to duct surfaces and does not necessarily enter the living space. It is important to keep in mind that dirty air ducts are only one of many possible sources of particles that are present in homes. Pollutants that enter the home both from the outdoors, as well as from indoor activities such as cooking, cleaning, smoking, or just moving around, can cause greater exposure to contaminants than dirty air ducts. Moreover, there is no evidence that a light amount of household dust or other particulate matter in air ducts poses any risk to your health.

In 1989, the National Air Duct Cleaners Association (NADCA) was formed by members of the duct cleaning industry. This organization adopted a standard in 1992 entitled: *NADCA Standard 1992-01, Mechanical Cleaning of Non-Porous Air Conveyance System Components*. This standard provides performance requirements and evaluation criteria for the mechanical cleaning of non-porous ductwork, fans, coils, and other non-porous components of commercial and residential air conveyance systems.

16.1 Duct Cleaning Methods

Methods of duct cleaning vary, although standards have been established by industry associations concerned with air duct cleaning. Typically, a service provider will use specialized tools to dislodge dirt and other debris in ducts, and then vacuum them out with a high-powered vacuum cleaner. Common duct cleaning methods include: (1) Contact vacuuming, (2) Air sweeping and (3) Power brushing.

Contact Vacuum Method:

Contact vacuuming involves cleaning the interior duct surfaces by way of existing openings and outlets or, when necessary, through openings cut into the ducts. The vacuum unit should only use HEPA (High Efficiency Particle Air) collection equipment; conventional equipment may release extremely fine particles into the atmosphere, instead of gathering them.

Starting at the return side of the system, the vacuum cleaner head is inserted into the section of the duct to be cleaned at the opening furthest upstream, and then the vacuum cleaner is turned on. Vacuuming proceeds downstream slowly enough to allow the vacuum to pick up all dirt and dust particles.



Contact vacuuming usually requires larger access windows than other methods, in order to allow the cleaning equipment to reach into the last corner of the duct. The distance between access hatches depends on the hovering equipment and the target distance from the opening. The head of the vacuum cleaner is introduced into the duct using the nearest opening at the beginning of the duct network. Hovering then starts, following the direction of air flow, and slowly enough to capture and gather up all the dirt.

Air Sweep Method:

In the air sweep or air washing method, a vacuum collection unit is connected to the downstream end of the duct section. The vacuum unit should use HEPA filtering, if it is exhausting into an occupied space. The isolated section of duct being cleaned should be subjected to a minimum of 1" negative air pressure to draw loosened materials into the vacuum collection system. Take care not to collapse the duct.

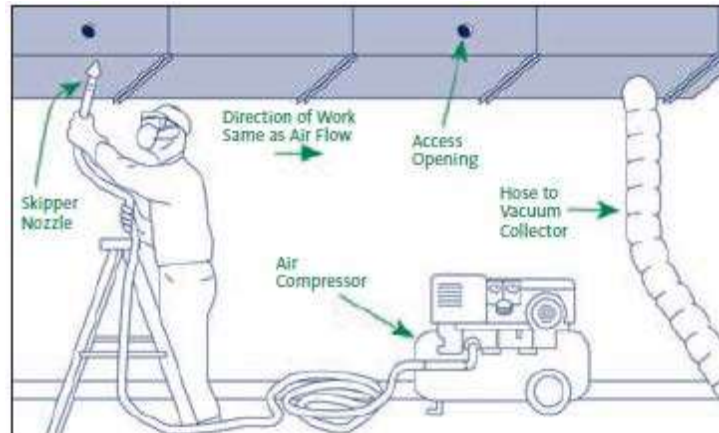

Compressed air is then introduced into the duct through a hose equipped with a skipper nozzle. This nozzle is propelled by the compressed air along the inside of the duct. For the air washing method to be effective, the compressed air source should be able to produce between 160 and 200 psi air pressure and should have a 20-gallon receiver tank. This method is most effective in cleaning ductwork no larger than 24" × 24" inside dimensions. Inspection of each duct section and related components is performed to determine whether the duct is clean.

Power (Mechanical) Brushing Method:

In the power brushing method, a vacuum collection unit is connected to the duct in the same way as with the air sweep method. Pneumatic or electric rotary brushes are used to dislodge dirt and dust particles, which become airborne and are then drawn into the vacuum unit. Brushing operations will usually require larger access openings than the previous method. Nevertheless, fewer openings are needed. Certain types of mechanical brushes can reach up to 24 ft. in both directions.

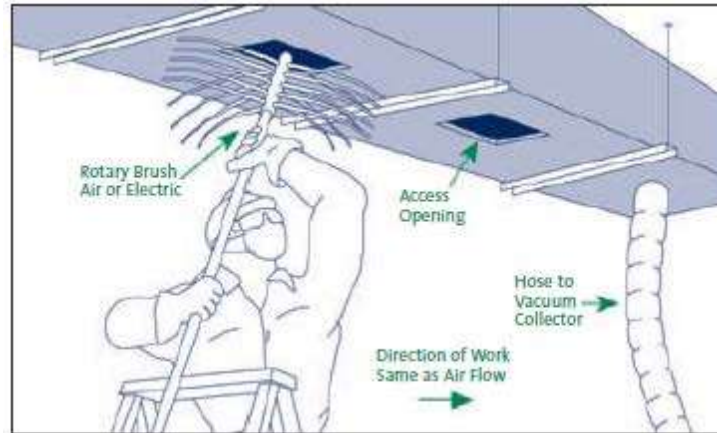

Inspection of each duct section and related components is performed to determine if the duct is clean. When the section of duct is clean, the brush is removed from the duct and inserted through the next opening, where the process continues.

Other Cleaning Variations

The service provider may propose applying chemical biocides, designed to kill microbiological contaminants, to the inside of the duct work and to other system components. Some service providers may also suggest applying chemical treatments (sealants) to encapsulate or cover the inside surfaces of the air ducts and equipment housings because they believe it will control mold growth or prevent the release of dirt particles or fibers from ducts. These practices have yet to be fully researched and you should be fully informed before deciding to permit the use of biocides or chemical treatments in your air ducts.

16.2 Coordination between Design Specialties

The process of design review includes a spot check to verify that the mechanical design is coordinated with the electrical, structural, and architectural design. Many of the following coordination checks will ensure energy efficiency in addition to verifying systems integration:

1. Is the structural support adequate in the areas where mechanical equipment will be located?
2. Do the architectural and structural details provide the necessary sound isolation and moisture protection in the mechanical areas?
3. Are the intake and exhaust penetrations through the walls adequately sized to prevent high pressure drops and moisture penetrations?

4. Are chase sizes large enough to allow adequately sized ductwork?
5. Are the structural clearances around chases and other areas with large duct and piping mains sufficient to allow the systems to be installed without high pressure drops?
6. Is there sufficient space above the ceiling and below the structure to allow the necessary mechanical system to be routed in conjunction with the electrical, plumbing and specialty systems without an excessive number of offsets and/or restricted duct sizes?
7. Have general rules been established for routing ducts, pipes, conduits and specialty systems through the ceiling cavity? If so, do they meet the requirements of the mechanical systems?
8. Is there a suitable access route to allow worn-out equipment to be removed and new equipment to be installed? Does this route contain adequate structural strength to support the equipment that might be moved through it?
9. Are the electrical service requirements coordinated with the requirements of the mechanical systems in terms of voltage, capacity, reliability, and source? An air-handling system that has its fans powered by the emergency system, its Direct Digital Control (DDC) controllers powered by an Uninterruptible Power Supply, with an interlock circuit on normal power, may experience a few problems when there is a momentary power surge on the utility line.
10. If the project will use variable speed drives, who will specify them? If the drives require isolation transformers or line reactors, who is responsible for sizing and specifying them?
11. Have the motor horsepower requirements changed since design development?
12. Has the type of starter that will be used for large machinery been coordinated with the electrical designer? Often, changing the type of starter or the voltage that is used to serve a large motor can improve electrical system performance and reduce first costs.

These coordination issues have ripple effects with significant implications for energy and resource conservation. For example, if a coordination problem between a mechanical system and a structural element is not resolved at the design stage, the field solution may require additional fittings. These fittings will introduce pressure drops that will persist for the life of the system or possibly the life of the building. As another example, consider an equipment room with a poor access route. The lack of suitable access may delay the replacement of an existing, outdated piece of equipment with a more efficient machine, simply because the cost to bring the new equipment into the building is too high.

Summary

General rules for duct design:

1. Air should be conveyed as directly as possible to save space, power and material.
2. Sudden changes in directions should be avoided. When not possible to avoid sudden changes, turning vanes should be used to reduce pressure loss.
3. Diverging sections should be gradual. Angle of divergence should be $\leq 20^\circ$.
4. Aspect ratio should be as close to 1.0 as possible. Normally, it should not exceed 4.
5. Air velocities should be within permissible limits to reduce noise and vibration.
6. Duct material should be as smooth as possible to reduce frictional losses.
7. Round ducts require 27% less metal per unit of air-handling capacity than rectangular ducts and have lower installation costs, which may result in substantial capital cost savings.
8. Rectangular metal ducts are the most flexible when it comes to fitting them within limited spaces and are used in many duct systems with pressures under 2.0 in-WC, particularly when the installing contractor has a sheet metal shop.
9. Leaks with medium- and high-pressure systems can create considerable noise. Sealing materials include gaskets, pressure-sensitive tapes, embedded fabrics, mastics, and liquids.

Below are excerpts of typical ductwork layouts from actual projects.

Annexure

TYPICAL DUCT LAYOUTS

DUCTWORK WITH SQUARE DIFFUSERS

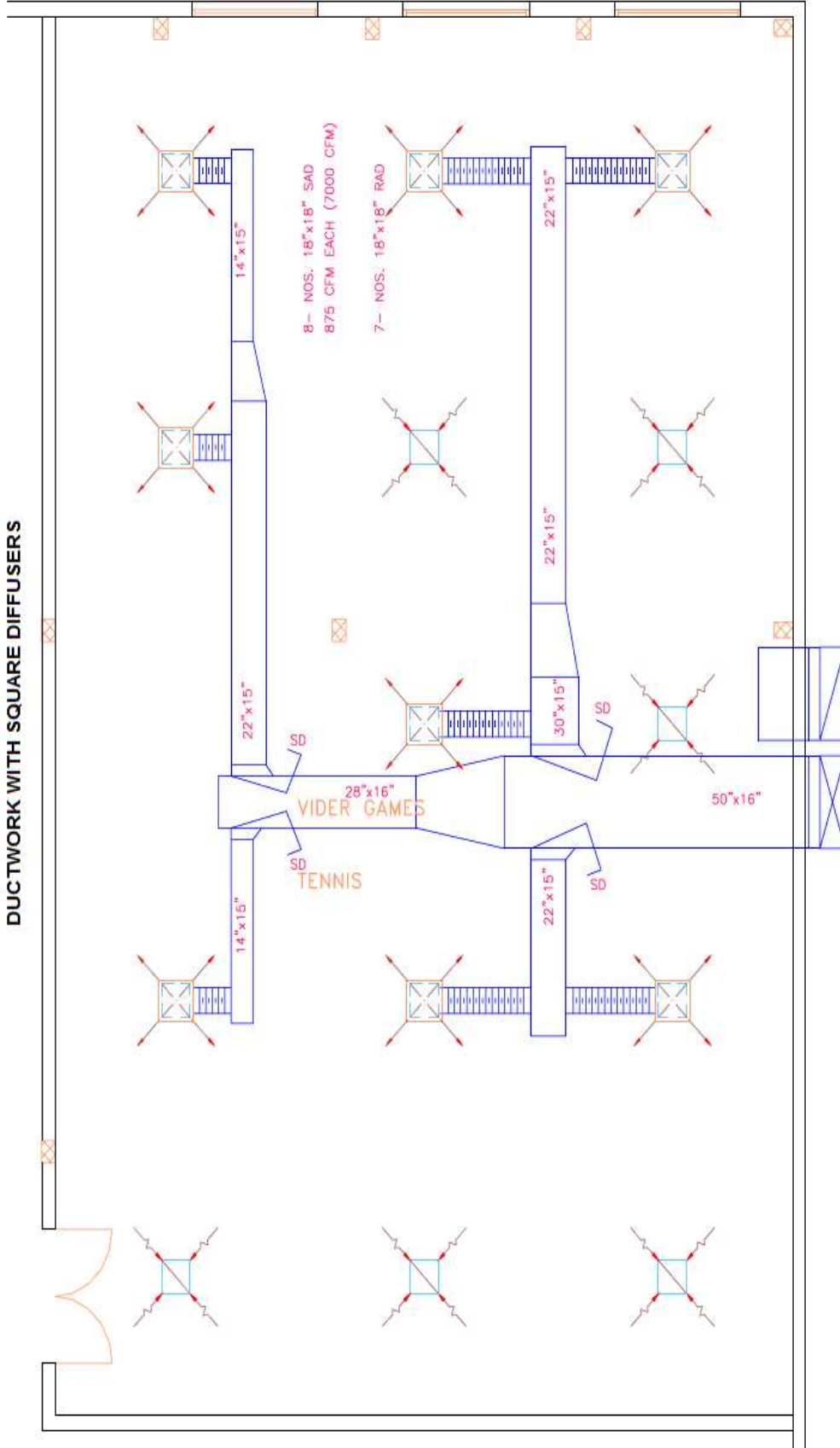

DUCTWORK WITH LINEAR DIFFUSERS

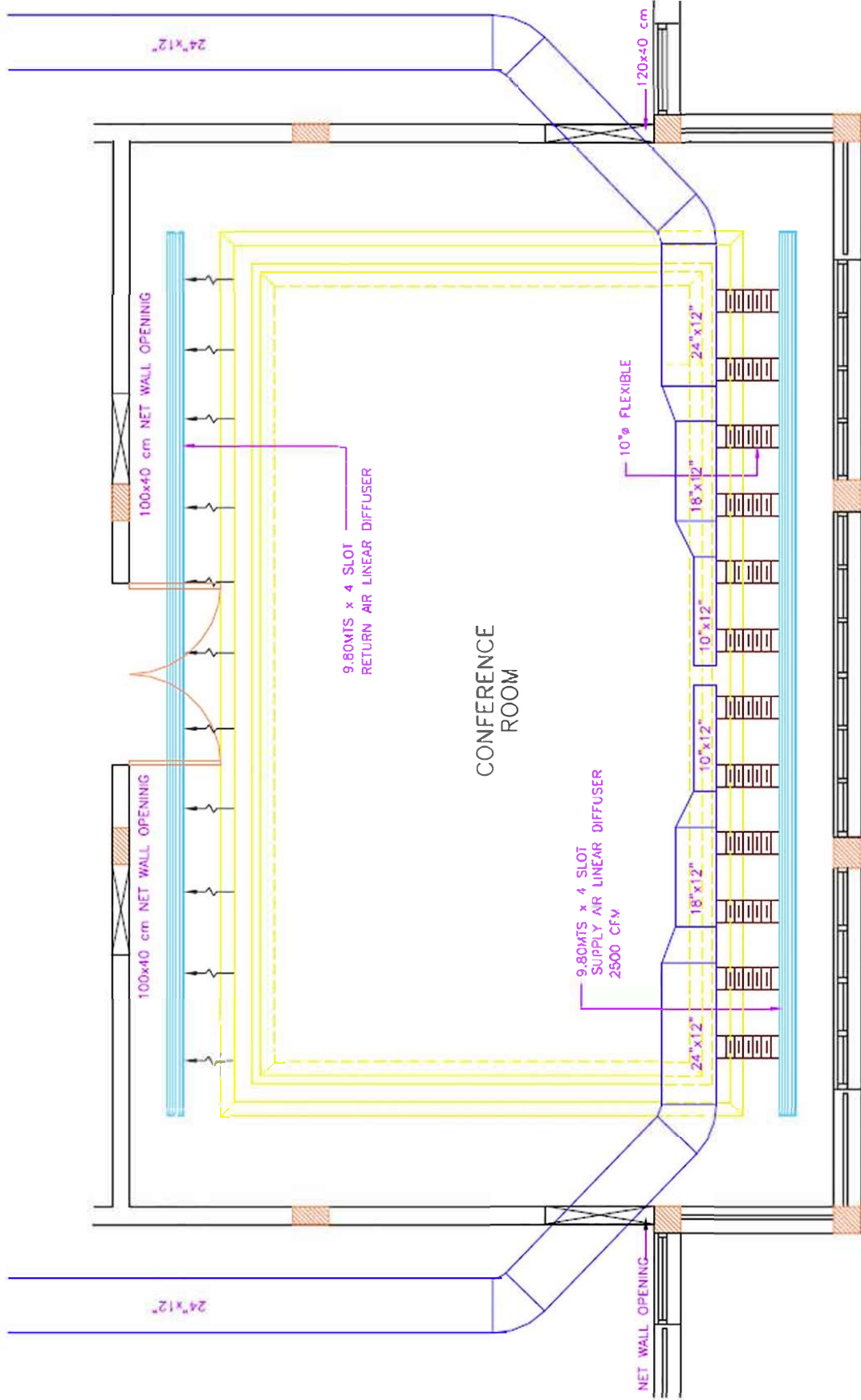

DUCTWORK WITH ROUND DIFFUSERS

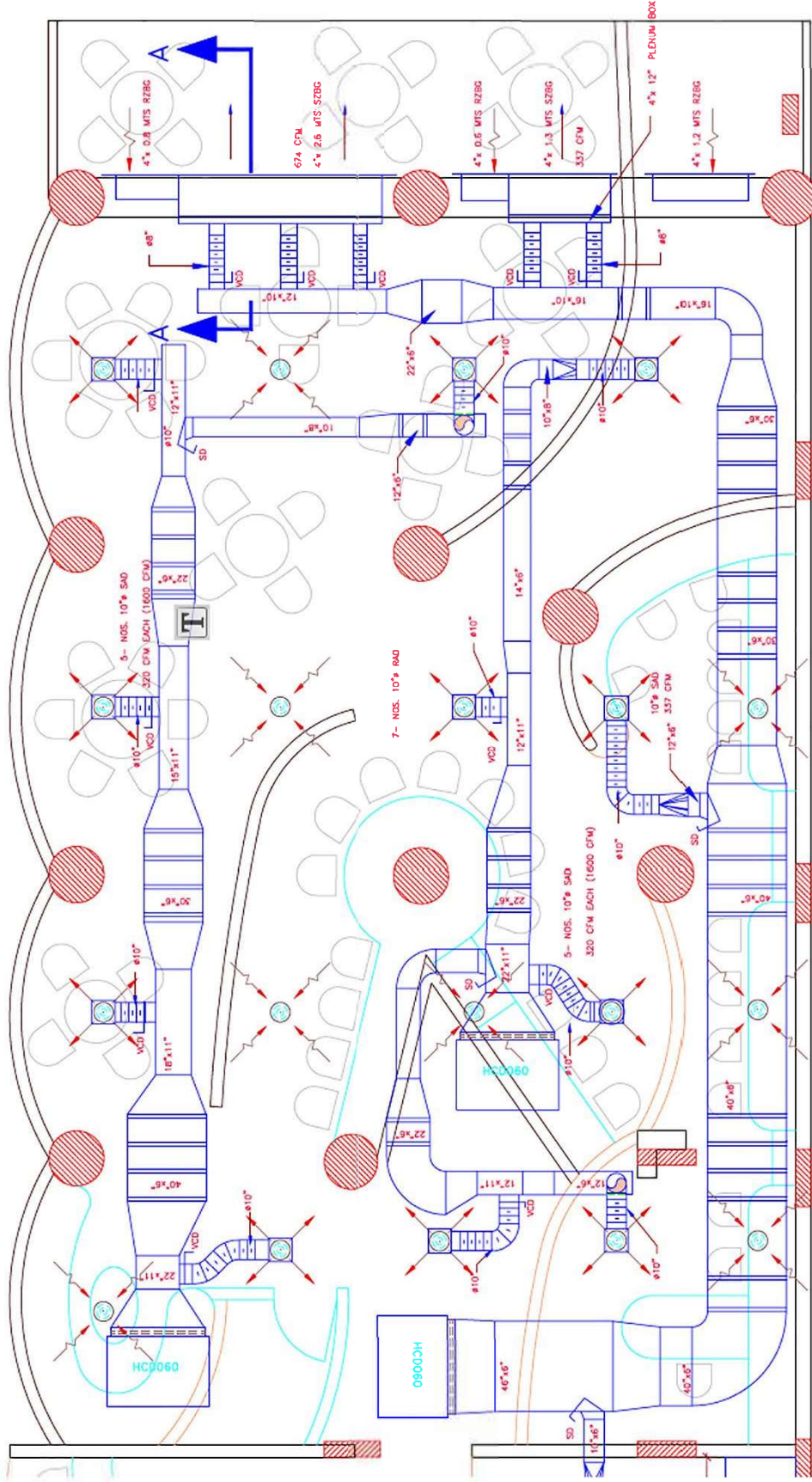

ROOFTOP PACKAGE UNIT WITH DUCTWORK

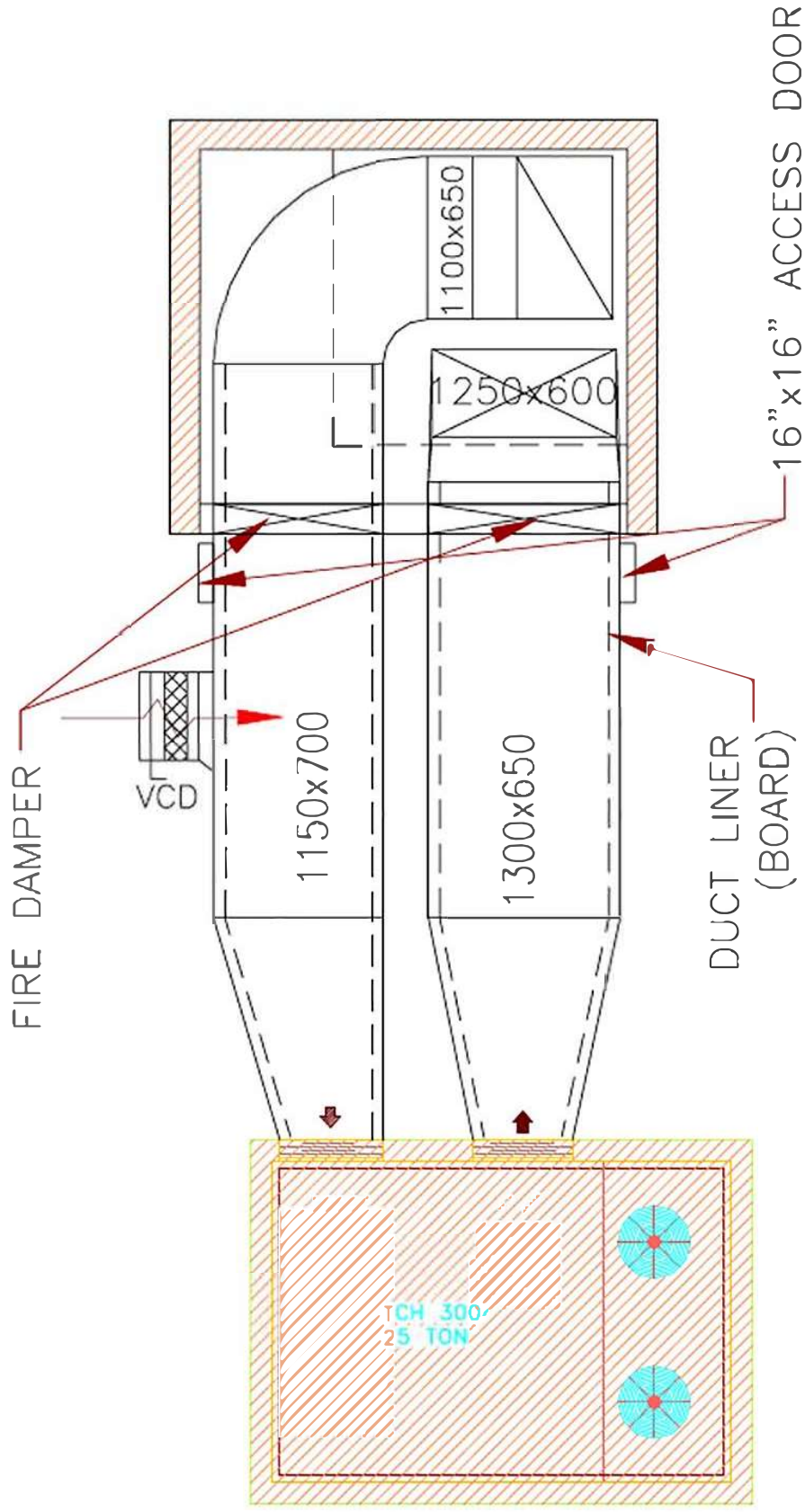

ROOFTOP PACKAGE UNIT WITH DUCTWORK (SIDE VIEW ELEVATION)

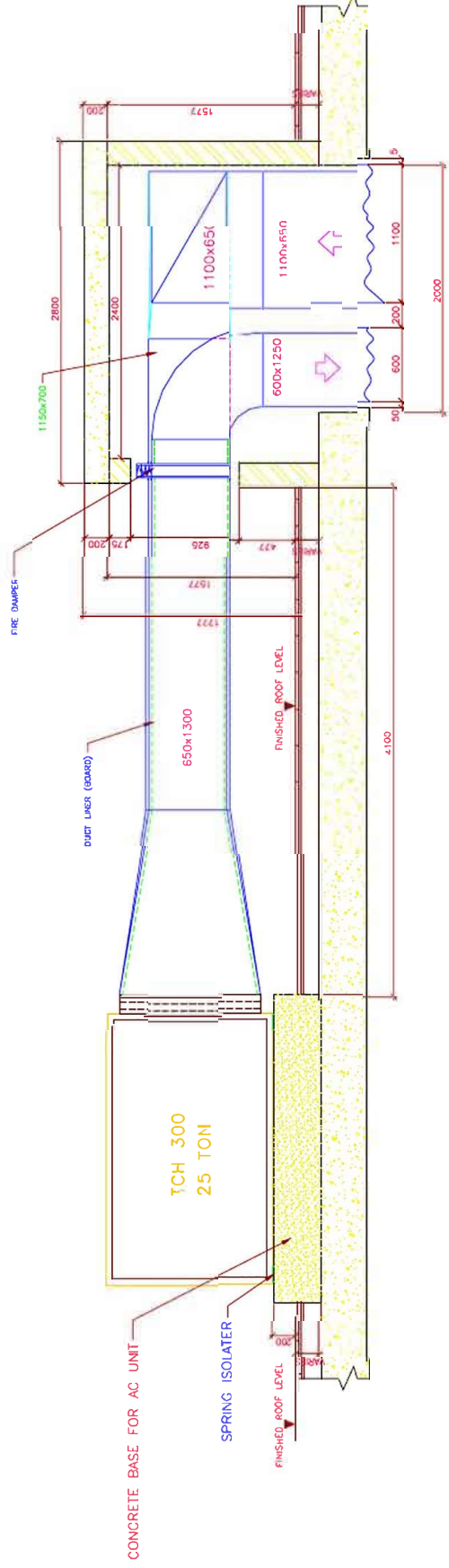

Coordination between ductwork and structural element



TYPICAL DUCT FABRICATION AND SUPPORTING

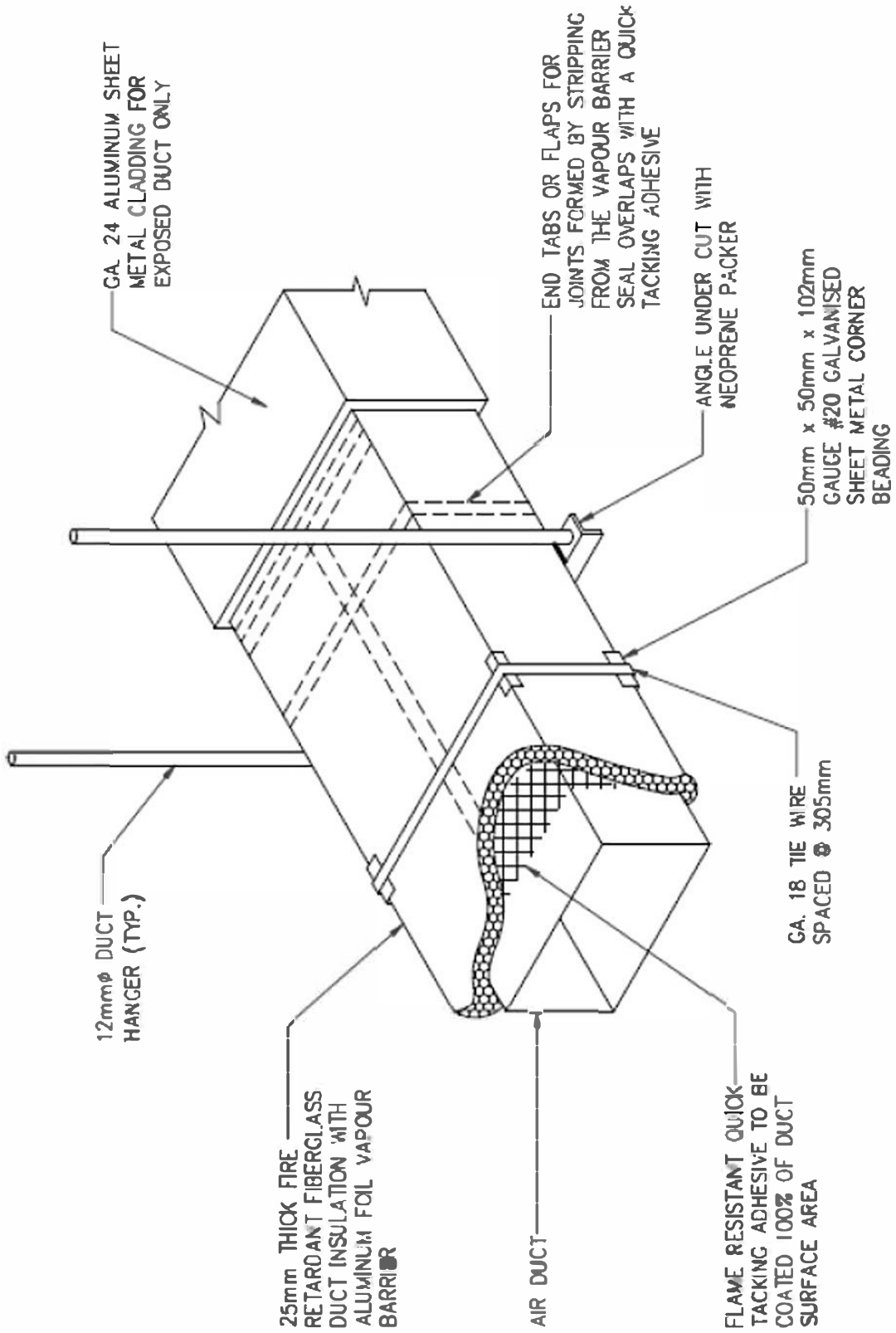

ROUND DUCT FITTINGS & TRANSITIONS

Round Duct Fittings and Transitions

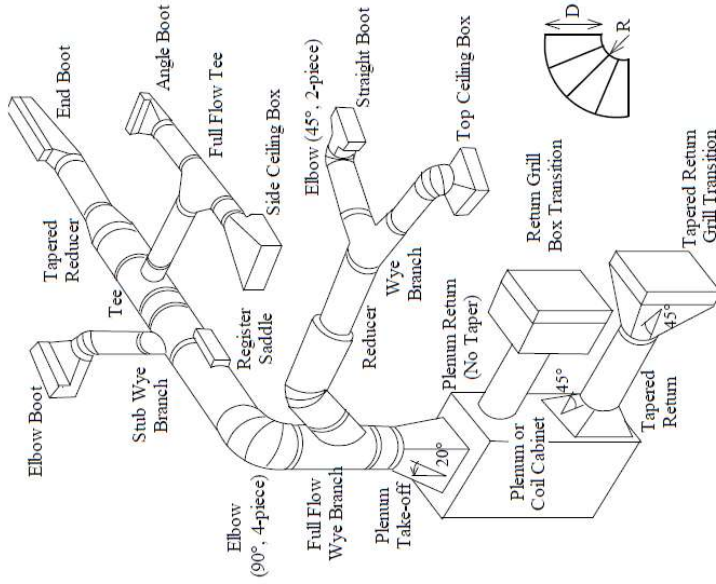

Fitting Type	Eqv. Length @ $\Delta h/L=0.1"/100'$		Eqv. Length @ $\Delta h/L=0.3"/100'$	
	8" \varnothing Dia.	12" \varnothing Dia.	8" \varnothing Dia.	12" \varnothing Dia.
Std. 90°L (R/D=.75)	16	30	18	22
90°L (R/D=1.5)	8	15	10	16
Std. 45°L (R/D=.75)	11	18	12	21
45°L (R/D=1.5)	4	6	5	7
Tapered (45°) Reducer	4	5	4	6
Non-tapered Reducer	8	14	9	16
Tee (branch)	34	60	39	67
Full Flow Tee (branch)	13	22	14	24
Wye	8	8	14	19
Stub Wye	17	29	19	43
Full Flow Wye	14	24	16	27
Straight Boot	5	6	6	8
End Boot	30	55	35	60
Elbow Boot	20	30	21	30
Register Saddle	35	60	40	65
Top Ceiling Box	20	35	23	40
Plenum Take-off (20°)	13	22	14	24
45° Tapered Plen. Ret.	10	18	12	20
No-taper Return	28	50	31	55
Return Grill Box	13	23	15	25
Tapered (45°) Ret. Grill	6	10	7	11

RECTANGULAR DUCT FITTINGS & TRANSITIONS

Rectangular Duct

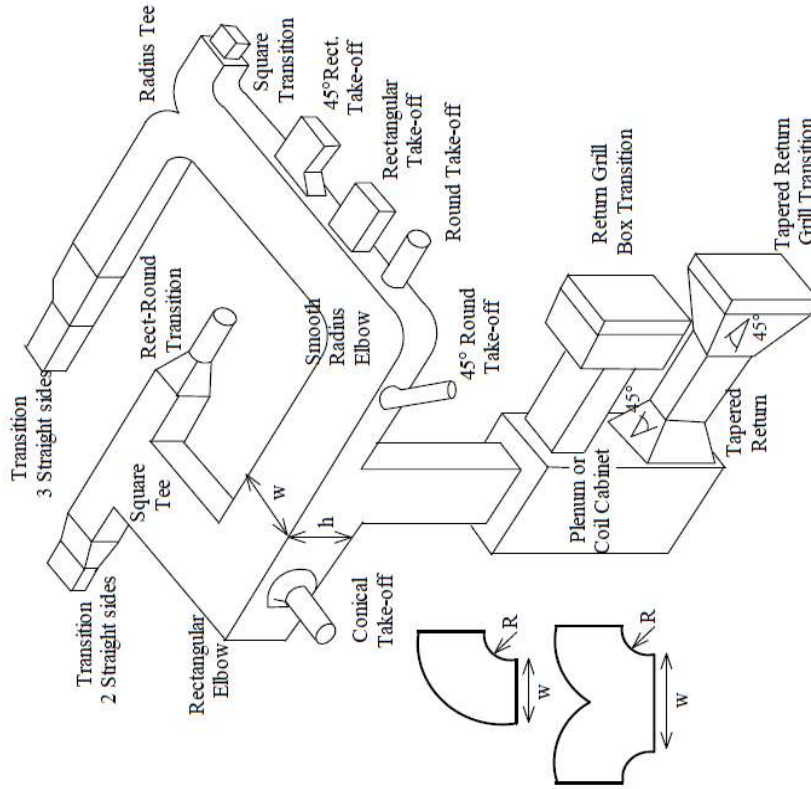

Fitting	Eqv. Length @ $\Delta h/L=0.1''/100''$		Eqv. Length @ $\Delta h/L=0.3''/100''$	
	w/h=1	w/h=4	w/h=1	w/h=4
Rectangular Elbow	65	90	70	100
Rect. Elbow with Vanes	14	14	25	25
45° Rectangular Elbow	18	27	20	30
Radius Elbow (R/w=.75)	24	40	27	45
Radius Elbow w. Vanes	2	4	2	5
Square Tee	50	90	55	100
Square Tee w. Vanes	16	30	18	34
Radius Tee (R/w=1.5)	16	30	18	34
(Base L _{eqv} on outlet size)	A _{in} /A _{out} =2	A _{in} /A _{out} =4	A _{in} /A _{out} =2	A _{in} /A _{out} =4
Square Transition	12	13	19	21
3-Straight Side Transition	5	5	5	5
2-Straight Side Transition	5	5	5	5
Return Grill Box	19	20	21	22
Plenum Outlet (no radius)	40	40	44	44
Tapered (45°) Ret. Grill	8	9	9	10
	A _{in} /A _{out} =0.5	A _{in} /A _{out} =0.25	A _{in} /A _{out} =0.5	A _{in} /A _{out} =0.25
45° Tapered Plen. Ret.	15	29	17	32
No-taper Return	28	50	31	55
	8" ∅ Dia.	12" ∅ Dia.	8" ∅ Dia.	12" ∅ Dia.
Round Take-off	35	60	40	70
45° Round Take-off	17	30	20	40
Conical Take-off	25	43	28	48
	Q _{To} /Q _M =.1	Q _{To} /Q _M =.4	Q _{To} /Q _M =.1	Q _{To} /Q _M =.4
Rectangular Take-off	48	52	55	60
45° Rect. Take-off	50	55	60	65

LOW PRESSURE DUCTWORK WITH VAV TERMINAL BOX

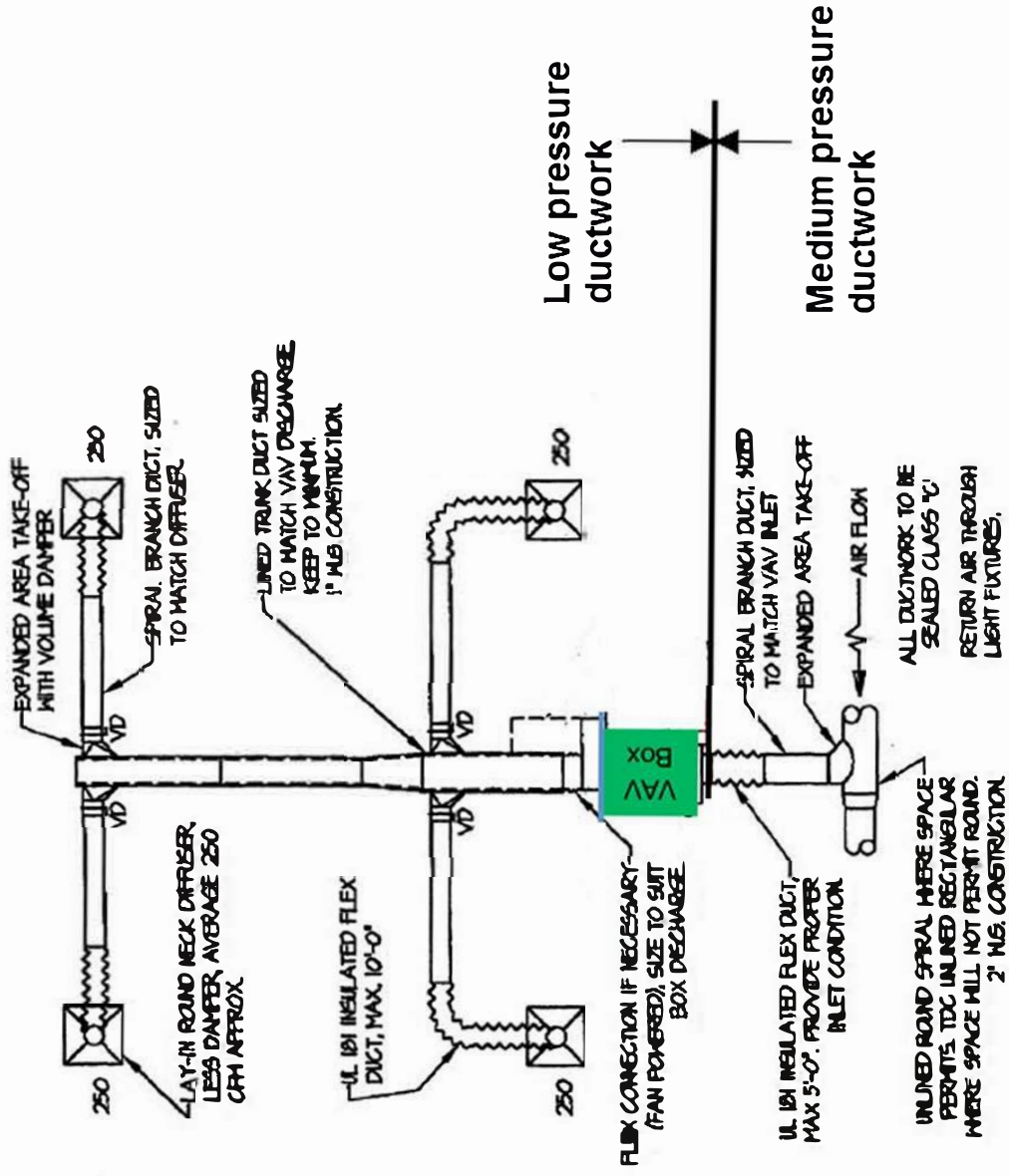

DUCTWORK SYMBOLS

		SUPPLY DUCT (UP & DOWN)		SUPPLY TOP REGISTER OR GRILLE (WALL TYPE)
		EXHAUST DUCT (UP & DOWN)		EXHAUST OR RETURN CEILING REGISTER OR GRILLE
		RETURN DUCT (UP & DOWN)		EXHAUST OR RETURN BOTTOM REGISTER OR GRILLE (WALL TYPE)
		ROUND AND SQUARE 4-WAY CEILING DIFFUSERS		EXHAUST OR RETURN REGISTER OR TOP GRILLE (WALL TYPE)
		SQUARE 3-WAY CEILING DIFFUSERS		VANED ELBOW & AIR SPLIT TYPE DUCT TAKE-OFF
		SQUARE 2-WAY CEILING DIFFUSERS		CONNECT NEW DUCT TO EXISTING DUCT
		SQUARE 1-WAY CEILING DIFFUSERS		INCLINED RISE, IN DIRECTION OF AIR FLOW
		LINEAR SLOT DIFFUSER		INCLINED DROP, IN DIRECTION OF AIR FLOW
				LIMIT OF DEMOLITION

Standard Sheet Metal Work Symbols

SYMBOL MEANING	SYMBOL	SYMBOL MEANING	SYMBOL
POINT OF CHANGE IN DUCT CONSTRUCTION (BY STATIC PRESSURE CLASS)		SUPPLY GRILLE (SG)	
DUCT (1ST FIGURE, SIDE SHOWN 2ND FIGURE, SIDE NOT SHOWN)		RETURN (RG) OR EXHAUST (EG) GRILLE (NOTE AT FLR OR GLG)	
ACOUSTICAL LINING		SUPPLY REGISTER (SR) (A GRILLE + INTEGRAL VOL. CONTROL)	
DUCT DIMENSIONS FOR NET FREE AREA		EXHAUST OR RETURN AIR INLET CEILING (INDICATE TYPE)	
DIRECTION OF FLOW		SUPPLY OUTLET, CEILING, ROUND (TYPE AS SPECIFIED) INDICATE FLOW DIRECTION	
DUCT SECTION (SUPPLY)		SUPPLY OUTLET, CEILING, SQUARE (TYPE AS SPECIFIED) INDICATE FLOW DIRECTION	
DUCT SECTION (EXHAUST OR RETURN)		TERMINAL UNIT, (GIVE TYPE AND/OR SCHEDULE)	
INLET, RISE (R) OR DROP (D) ARROW IN DIRECTION OF AIR FLOW		COMBINATION DIFFUSER AND LIGHT FIXTURE	
TRANSITIONS: GIVE SIZES, NOTE F.O.T. FLAT ON TOP OR F.O.B. FLAT ON BOTTOM IF APPLICABLE		DOOR GRILLE	
STANDARD BRANCH FOR SUPPLY & RETURN (NO SPLITTER)		SOUND TRAP	
SPLITTER DAMPER		FAN & MOTOR WITH BELT GUARD & FLEXIBLE CONNECTIONS	
VOLUME DAMPER		VENTILATING UNIT (TYPE AS SPECIFIED)	
MANUAL OPERATION		UNIT HEATER (DOWNBLAST)	
AUTOMATIC DAMPERS		UNIT HEATER (HORIZONTAL)	
MOTOR OPERATED		UNIT HEATER (CENTRIFUGAL FAN) PLAN	
ACCESS DOOR (AD)		THERMOSTAT	
ACCESS PANEL (AP)		POWER OR GRAVITY ROOF VENTILATOR-EXHAUST (ERV)	
FIRE DAMPER: SHOW VERTICAL POS. SHOW HORIZ. POS.		POWER OR GRAVITY ROOF VENTILATOR-INTAKE (SRV)	
SMOKE DAMPER		POWER OR GRAVITY ROOF VENTILATOR-LOUVERED	
CEILING DAMPER OR ALTERNATE PROTECTION FOR FIRE RATED VENT		LOUVERS & SCREEN	
TURNING VANES			
FLEXIBLE DUCT			
FLEXIBLE CONNECTION			
GOOSENECK HOOD (COWL)			
BACK DRAFT DAMPER			



Sheet Metal and Airconditioning Contractors
National Association, Inc